

SLP[®]

STREET LEGAL PERFORMANCE

2015

Parts Catalog

Late model muscle cars,
Trucks and SUVs



About SLP

Providing OEM-quality performance, handling and appearance components for late model Detroit-based Performance Cars (Camaro, Corvette, Mustang, Challenger and Charger) and Full-Size GM Trucks and SUVs is what SLP is all about.

Prior to forming SLP and dating back to 1970, Ed Hamburger first became well known for his unique product line of performance engine components, developed exclusively for small block Chrysler-equipped race car applications. His company was also one of the first Chrysler Direct Connection Performance Parts Distributors in the country. That company was sold in 1988.

The next chapter on this interesting journey, which eventually led to forming SLP, was the creation of another well-known company in the Performance Parts Industry, Hamburger's Oil Pans, which Ed formed in 1975. Over the next 20 years, Hamburger's Oil Pans was the dominant performance oil pan used in Winston Cup (now known as Sprint Cup) racing and NHRA Drag racing, with over 85% of participating race cars using his oil pans. By the time the company was sold to another well known performance parts manufacturer in 1995, more records were set and races won by cars equipped with Hamburger's Oil Pans in sanctioned motorsports events throughout the country, than any other oil pan manufacturer at that time.

SLP's initial claim to fame was having the distinction of being the very first company in the Performance Parts Industry to develop and manufacture a totally integrated and emission legal (in all 50 states) performance package providing a serious performance gain, while also improving fuel economy for late model V8 Camaros and Firebirds. The package included SLP's stainless steel headers,

SLP's stainless steel cat-back exhaust system, SLP's high-flow intake runners, SLP's cold air induction system and an SLP revised PCM E-Prom. Installing this package on a TPI 350 CID engine-equipped 1988 Camaro resulted in a 50 horsepower gain, a one full second reduction in 0-60 MPH times, a 6 MPH increase in top speed, and a 2 mile per gallon improvement in highway fuel economy. The next milestone for SLP was the addition of limited production specialty vehicles to the already impressive line of performance parts. SLP's initial efforts were rewarded with the GM-approved 4th generation RPO (Regular Production Option) Camaro SS and Firebird Firehawk/WS6/Comp TA Specialty Vehicle programs that began in 1995. Over the next eight years SLP produced over 55,000 GM specialty vehicles for GM and its Chevy and Pontiac dealers, out of its 140,000 sq. ft. Montreal-based assembly facility. They included Camaro SS and RS models, along with the Firebird-based Firehawk, WS-6 and Comp T/A models.

In August of 2002, GM ended production of the 4th generation Camaro/Firebird, along with SLP's Camaro SS and Firehawk Specialty Vehicle Programs. SLP then focused on expanding their product line of performance, handling and appearance products for all late-model Detroit-based performance cars including Camaro, Corvette, Mustang, Charger, Challenger, and Full-Size GM Trucks and SUVs.

Once GM announced its intention of producing a 5th Generation Camaro, to be introduced in late 2009 as a 2010 model, SLP started product development of it's own powertrain, suspension and body components for their upcoming 5th Generation Camaros.



CAMARO – 2010-2015 5th Generation V6/V8	4
V8 Camaro Supercharger	5
Unique features of SLP's All-New ROOTS-TYPE Supercharger	6
SLP Blackwing™ Cold Air Induction Systems	7
2010-2015 Camaro Performance Components	8
Exhaust Systems and Components	9
2010-2015 Camaro Exhaust Systems and Components	9
2010-2015 Camaro PowerFlo V8 Headers	10
2010-2015 Camaro Driveline Components	11
2010-2015 Camaro Chassis Components	12
Braking Components	13
Appearance Accessories	13

F-BODY – 1982-2002 Camaro, Camaro SS, Firebird, Firehawk	15
F-Body Cold Air Induction Systems	16
F-Body Performance Components	17
1993-2002 F-Body PowerFlo™ Long-Tube Headers	18
1993-2002 F-Body Exhaust Systems and Components	19
Driveline Components	20
Suspension Components	20
Braking Components	21
Appearance Accessories	21
Interior Accessories	22
F-Body Car Covers	22

CORVETTE – 1985-2015 C4-C6, Z06 Grand Sport, ZR1	23
C4/C5/C6/Z06 Cold-Air Induction Systems	24
C6 Blackwing Cold Induction Systems	24
Performance Components	26
C6 Header Packages	27
Crossover Assemblies	28
C6 Exhaust Systems	28
C5 Exhaust System	29
Driveline Components	30
C5 and C6 Appearance Accessories	30
Interior Accessories	30

G8 – 2008-2009-1/2 GT/GXP	31
2008-2009 G8 Performance Components	32
Long-Tube Headers	32
Axle-Back Exhaust Systems	33

GTO – 2004-2006	34
Performance Components	35
Long-Tube Headers	35
Exhaust Systems	36
Braking Components	36

2007-2015 900 Series Silverado, Sierra, Avalanche, Tahoe, Suburban, Yukon/XL/ Denali, Escalade	37
GM Truck/SUV Supercharger	38
Cold Air Induction Systems	39
Performance Components	39
Exhaust Systems	40
Appearance	42

Trailblazer SS	43
Exhaust System with Rear Fascia Panel	44
Appearance	44

Accessories	45
--------------------	-----------

Engine Components	46
Windage Tray Spacers	47
LS1 Oil Pump	47
Flow Booster	47
Balancer/Pulleys	47
Timing Chains	49
160° Thermostats	49

Exhaust System Components	50
Bullet-Style Resonators	51
Bullet-Style Mufflers	51
Universal-Style Mufflers	51
Universal-Style Mufflers	52
Catalytic Converters	52
Premium Exhaust Clamps	53
Tips	53

New Products Coming Soon!



CAMARO

2010-2015 5th Generation V6/V8



V8 Camaro Supercharger with Available 3/36 Powertrain Warranty

The SLP Stage 1 supercharger kit for the 2010-2015 Camaro delivers more than 500 HP and 500 lb-ft of tire-shredding torque to the ground (when installed on an LS3). Even after the industry-conservative drivetrain loss of 12%, the SLP kit yields 575 HP (510 HP w/L99) at the crank, utilizing 91 octane pump gas, stock exhaust manifolds, stock catalytic converters, and the factory air box. Highly-developed SLP calibration guarantees the absence of any shortcuts that might risk the safety of your engine, vehicle, or legality.

The Stage 1 kit, (92000A), contains everything necessary to install the kit**.

*If installed on L99 engines (automatic transmission Camaro engine), the installer will need to verify which DOD (Displacement-On-Demand) valley plate was installed at the factory. GM used two different styles of DOD plates during production. The SLP 92000A kit was designed to fit all LS3 engines, but only one style of L99 valley plate. Please see the online instructions regarding identification of DOD plates. If your vehicle was equipped with the non-supported valley plate design, please call SLP Sales/ Customer Service at (855) SLP-PERF (855.757.7373) during regular business hours for a complimentary correct valley plate (SLP P/N 620053, GM P/N 12571609).

**If being installed on a 2014 or 2015 Camaro, SLP Hood Heat Extractor must be purchased separately (P/N 620032).

NOTE: SLP's optional powertrain warranties are NOT third-party warranties and have NO DEDUCTIBLE.

Available Alternative Pulleys and Belts

PULLEY P/N	DIAMETER	BELT P/N
90 46 30127	74 mm	904068126
HH-6K98-AA	98 mm (stock)	904068124
92002	91 mm	904068128



90001	Optional 3-year/36,000-mile powertrain warranty, Stage 1 only
620024	Tuner Kit
92000A	Supercharger Package, 2010-2015 V8, SLP TVS 2300, black finish, manual transmission
620032*	Heat Extractor Kit

*2014+ needs Hood Heat Extractor. P/N: 620032.

SLP Branded Engine Coil Covers



620038 Engine Coil Covers

Fits 2010-2015 Camaro SS and 1LE models .

OE quality and Injection molded in black with pad printed silver "SLP" logo. Designed to fit supercharged or naturally aspirated applications. Enhances the appearance of the engine compartment. Adequate clearance for street use Stainless steel 12-point fasteners easy bolt-on installation.

To enhance the underhood appearance of your 2010-2015 SS and 1LE Camaro, SLP now offers OE-quality, injection molded SLP branded Engine Coil Covers. Designed to replace the bulky one-piece factory engine cover, this two-piece set fits SLP TVS 2300 supercharger packages and naturally aspirated applications. Featuring a pad printed silver "SLP" logo on driver and passenger sides,



each engine cover is manufactured of the highest quality emphasizing our unique design and proper fitment while keeping its form even in the high-heat environment of your engine bay. Easy bolt-on installation, all necessary hardware and detailed installation instructions are included. Backed by our 90-day SLP parts limited warranty, these new engine coil covers are a must have for any Camaro enthusiast!

NOTE: Use with SLP Supercharger Part #92000A, #92000B, #92000C and #620024

NOTE: Fits most LS-based engine applications, trimming may be necessary for proper fitment Note: Requires a fuel line quick disconnect tool

Unique features of SLP's All-New ROOTS-TYPE Supercharger

- Designed from a clean sheet of paper to meet or exceed all OEM design, engineering, and manufacturing standards
- Direct drive rotor pack eliminates the need for a jackshaft, extra bearings, extra pulleys, and rear belt
- Intake manifold ports are port-matched (designed into casting) to the cylinder head ports for greater airflow
- Easiest supercharger installation on the market; installs in less than 8 hours
- Includes OEM-quality plug-and-play wire harnesses, pre-bent and pre-cut hoses
- New 2 bar MAP sensor allows more accurate fuel delivery under boost conditions
- Patented distinctive SLP outer case design mimics the inner helix design of the rotor pack
- Intercooled with high-flow circulating pump and oversized coolant reservoir to maximize thermal capacity
- Includes new belt tensioner with increased tension and greater travel compared to stock. Eliminates throwing belts even on 427 LS engines with 12 psi of boost
- Higher flow air intake tube and new bellows included in Stage 1 kits
- 5-bolt pulley mounting system is stronger than 4-bolt system used by competitors
- Includes Hand-Held Touch-Screen Programmer with SLP developed and preloaded custom PCM calibrations for each specific SLP supercharger package
- Most competitively priced TVS supercharger on the market. The SLP systems create the most horsepower per dollar.
- SLP's Camaro supercharger uses Eaton's TVS 2300 series rotor packs, the same rotor packs used in GM's ZR1 Corvette engine
- Injector bosses are cast into manifold at same angle as GM's manifold, providing optimum fuel delivery to the back of the valve for improved combustion and atomization of fuel
- 3-YEAR/36,000-MILE WARRANTY ON ALL SUPERCHARGER COMPONENTS
- E.O. #D-187-21

OEM-quality injection molded engine covers are designed for use on all 2010-2015 Camaros equipped with SLP's TVS Supercharger.



Heat Extractor Hood Insert

Looking for big horsepower without sacrificing your 2014-2015 Camaro SS or 1LE's factory image? Look no further! SLP has designed an OE-Quality Hood Heat Extractor Insert with Drip Tray for use with SLP's TVS 2300 Supercharger Packages. Designed to replace the factory hood insert for proper hood-to-supercharger clearance, simply unbolt and replace the stock heat extractor hood insert with SLP's new factory appearing insert. The unique design offers the same functionality as factory, and is injection molded in a black satin finish for proper hood fitment. It features a subtle "SLP" logo on top and underhood letting other bow-tie enthusiasts know that this Camaro means business! Backed by our 90-Day Parts Limited Warranty, and all necessary hardware and detailed installation instructions are included.

Note: Use with SLP Supercharger Packages Part #92000A, #92000B, #92000C and #620024.

Note: Installing an SLP Supercharger Package on 2014-2015 model year REQUIRES SLP's Hood Heat Extractor and replaces the factory hood heat extractor for proper supercharger-to-hood clearance.

620032 2014-2015 V8 SS/1LE Camaro Hood Heat Extractor with Drip Tray



SLP Blackwing™ Cold Air Induction Systems

SLP's Blackwing™ Cold Air Packages

SLP Blackwing™ Cold Air Induction kits are engineered and designed to maximize the air induction efficiency of your high-horsepower GM engine. These Blackwing™ cold air systems are manufactured from the highest quality materials to meet SLP's exacting standards. The GM factory air box is well-engineered for the average Camaro owner, but if you crave maximum engine performance through the entire RPM range, these kits are a must have! Combined with a LoudMouth™ cat-back exhaust system, the Camaro Blackwing™ cold air kits have shown gains in excess of 14 HP and 14 lb-ft of torque on naturally-aspirated LS engines.

All Blackwing™ kits use high-quality, free-flowing, reusable dry media filters. The products are designed to be easily removable should you ever need to return to stock.



620047

SLP Supercharged V8 Applications (2010-2015)

620047 2010-2015 V8 SS/1LE Camaro Blackwing™ Cold Air Induction Kit w/Black Filter (For SLP Supercharger)

620048 2010-2015 V8 SS/1LE Camaro Blackwing™ Cold Air Induction Kit w/Blue Filter (For SLP Supercharger)



620049

Naturally-Aspirated V8 Applications (2010-2015)

620049 2010-2015 V8 SS/1LE Camaro Blackwing™ Cold Air Induction Kit w/Black Filter

620050 2010-2015 V8 SS/1LE Camaro Blackwing™ Cold Air Induction Kit w/Blue Filter

Naturally-Aspirated V6 Applications (2010-2015)

620045 2012 - 2015 V6 Camaro Blackwing™ Cold Air Induction Kit w/Black Filter

620046 2012 - 2015 V6 Camaro Blackwing™ Cold Air Induction Kit w/Black Filter



620045

Drop-In High-Flow Filter for Factory Air Box (2010-2015)

21124 Blackwing™ High-Flow Air Filter, for use w/Stage 1 Cold Air Packages – unique calibration not required.



21124

2010-2015 Camaro Performance Components

Supercharger Boost Gauge

Includes custom SLP-faced Autometer mechanical boost gauge installed in a custom SLP gauge pod that mounts on the steering column. The face matches the stock Camaro gauges, is backlit, and displays both vacuum and boost pressure.



90550A Boost Gauge and Gauge Pod

90554 Gauge Pod Only

90555 Boost Gauge Only

Underdrive Pulley/Harmonic Balancers

Reduce engine accessory (water pump, alternator, and A/C compressor) drive speed by 25%, resulting in up to 6 additional horsepower and 4 ft-lbs of torque at the rear wheel. These pulleys incorporate a pair of extra-tall belt retention walls that eliminate belt slippage. Includes detailed installation instructions.

100230A 25% Underdrive Pulley/Harmonic Balancer, V8

100232A 25% Underdrive Pulley/Harmonic Balancer, V6



100232A – V6

100230A – V8

160° Lower-Temperature Thermostat

Reduces coolant temperature, easy to install, and requires no additional modifications. SLP 160-degree Lower Temperature Thermostats are a cost-effective way to improve your car's performance. V8 only.



100229 160° Thermostat, V8



Exhaust Systems and Components

Axle-Back Exhaust Systems

Available in three distinctive levels of rumble and volume, our engineers developed these Axle-Back Exhaust Systems to sound great on the street. Our LoudMouth III™ system features a pair of stainless steel mufflers, offers an aggressive rumble, but is only slightly louder than the stock Camaro exhaust. The LoudMouth II™ system features two stainless steel resonators with a rich and powerful muscular tone that's louder than LoudMouth III™. Both of these systems have little to no cabin resonance. For a more aggressive sound, bolt-on our LoudMouth™ system to vocalize your attitude.

All three systems provide a noticeable performance improvement and feature polished 304 stainless steel mufflers, a bolt-on design for easy installation, and include 4-inch diameter, dual-wall polished tips that fit the factory rear fascia openings.

All systems include necessary hardware and detailed installation instructions. Backed by our Limited Lifetime Warranty. Fits V6 and V8 Camaros.



Systems include clamps and all necessary installation hardware.

2010-2015 Camaro Exhaust Systems and Components

31200A	LoudMouth III™ with 4" Tips, V6
31210A	LoudMouth III™ with 4" Tips, V8
31202	LoudMouth II™ with 4" Tips, V6
31212	LoudMouth II™ with 4" Tips, V8
31201	LoudMouth™ with 4" Tips, V6
31211	LoudMouth™ with 4" Tips, V8



SLP LoudMouth™ Crossover Pipe Assemblies

Available in 2.5-inch or 3-inch diameter, stainless steel SLP LoudMouth™ X-Pipes are designed to maximize the performance of our headers and provide up to a 10 horsepower gain. They feature easy bolt-on installation and include all necessary hardware and detailed installation instructions. Backed by our Limited Lifetime Warranty. **V8 COUPES ONLY.**

30220	SLP LoudMouth™ V8, For Use with Stock Manifolds, 3-inch tailpipes
30223	SLP LoudMouth™, V8, For Use with Stock Manifolds and SLP Axle-Back Exhaust Systems #31212, #31212S, 2.5-inch tailpipes
30221	SLP LoudMouth™, V8, For Use with SLP PowerFlo™ Headers #30211, 3-inch tailpipes
30224	SLP LoudMouth™, V8, For Use with SLP PowerFlo™ Headers #30211 and SLP Axle-Back Exhaust Systems #31212, #31212S, 2.5-inch tailpipes



Muffler/Resonator Delete Kit

Manufactured from 3-inch stainless steel, SLP's LoudMouth™ V8 Camaro Muffler/Resonator Delete Kit requires no modification to our LoudMouth™ X-Pipe, allowing you to custom-tailor the sound of your vehicle's exhaust system. Easily switch back to the 3-inch mufflers to suit virtually any on or off-road application in a matter of minutes!

30222	Muffler Delete Kit, V8, For use with SLP LoudMouth™ Systems #30213, #30214, #30220, #30221, #30223, #30224
--------------	--



2010-2015 Camaro PowerFlo™ V8 Headers

V8 Camaro Long-Tube Headers

SLP's PowerFlo™ 2010-2015 V8 Camaro Long-Tube Headers feature 1-3/4-inch stainless steel primary tubes which are mandrel-bent and ceramic coated to keep heat in, exhaust velocity up, and under-hood temperatures down. All SLP PowerFlo™ Camaro headers are compatible with the stock emission-control equipment and use 3/8-inch thick OEM flanges to ensure a perfect fit and proper bolt retention. Header systems include our High-Flow Catalytic Converters which provide up to a 30 horsepower gain. All necessary hardware and installation instructions are included. Backed by our Limited Lifetime Warranty.

30211	Header Package, Polished Silver Ceramic Coated, 1-3/4-inch Long-Tube, 2010-2015 Camaro V8, Coupe and Convertible, w/Installation Kit/High-Flow Cats; use w/Stock H-pipe
30212	Header Package, Polished Silver Ceramic Coated, 1-3/4-inch Long-Tube, 2010-2015 Camaro V8, Coupe Only, w/Installation Kit/High-Flow Cats; use w/#30220, #30223
30213	Header Package, Polished Silver Ceramic Coated, 1-3/4-inch Long-Tube, 2010-2015 Camaro V8, Coupe Only w/Installation Kit/High-Flow Cats/LoudMouth™ X-Pipe
30214	Header Package, Polished Silver Ceramic Coated, 1-3/4-inch Long-Tube, 2010-2015 Camaro V8, Coupe Only w/Installation Kit/High-Flow Cats/LoudMouth™ X-Pipe; use w/#31212, #31212S (3- to 2.5-inch Tailpipes)
30216	Long-Tube Headers 1-3/4-inch use with stock H-pipe



All SLP Header Packages come with an installation kit.

NOTE: SLP's Header Packages are not legal for sale or use in CA on pollution-controlled motor vehicles. For off-road use only.

Spark Plug Socket

In order to make spark plug removal a little easier in the crowded F-body engine compartment, SLP has developed this modified Spark Plug Socket. Cut down to fit into extremely tight areas, the socket has had the square drive removed to allow the plug to protrude. The 5/8-inch socket is turned using an open or box end wrench on the hex base.

30102 Spark Plug Socket



2010-2015 Camaro Driveline Components

LS9/ZR1 Dual Clutch and Flywheel package

SLP's fully-balanced LS9/ZR1 Dual Clutch and Flywheel package was designed as a bolt-on replacement clutch assembly for your 2010-2015 LS3 equipped fifth-generation Camaro. It includes the GM ZR1 Corvette Twin Disc Clutch/Pressure Plate Assembly, SLP's new 6-bolt flange, steel billet flywheel, a new slave cylinder, and slave cylinder spacer. All hardware and installation instructions are included.

60020A LS9/ZR1 Dual Clutch and Flywheel Assembly, LS3 Camaro



Extreme-Duty Rear Axle Half-Shafts

SLP offers Extreme-Duty Rear Axle Half-Shafts for your 2010-2015 V8 Camaro. Designed to handle up to 1,400+ horsepower, these 30-spline half-shafts use chrome-molycenter bars, 108 mm (Porsche Turbo style) CV's, and bolt-on chrome-moly inner and outer stubs. They are a direct bolt-on that fits the stock hubs, and a must-have for SLP Supercharged Camaros.

64277A Half-Shafts



Heritage-Style 6-Speed Shifter Assembly

SLP's Heritage-Style 6-Speed Shifter Assembly for the 2010-2015 Camaro provides a classic look and a more positive feel while shifting. The shift lever is CNC-machined from a solid piece of billet 303 stainless steel and polished to a brilliant finish. Each shifter kit includes a white shift knob ball, new K-Prene bushings, all necessary hardware, and detailed installation instructions.

60055A Heritage-Style Shifter



Short-Throw Shifter Assembly and Leather-Wrapped Shift Knob

SLP's Short-Throw Shifter Assembly And Leather-Wrapped Shift Knob for the 2010-2015 Camaro provides a 20% reduction in shift lever throw and a more positive feel while shifting. The SLP shift lever will allow the use of the stock shifter knob or SLP's leather-wrapped shift knob. Machined from one solid piece of billet 303 stainless steel, and new K-Prene bushings are included.

60045A Short-Throw Shifter

60046A Shift Knob – SLP



Skip-Shift Eliminator

Decide for yourself what gear you want to be in! Dump that annoying first-to-fourth "skip-shift" that GM incorporates into every 6-speed with SLP's Skip-Shift Eliminator. This plug-in piece requires no additional modification to your vehicle. With it in place, you take complete control over gear selection. Easy installation instructions. V8 and ZL1 6-speed only.

21008 Skip-Shift Eliminator, V8/ZL1



NOTE: Not legal for sale or use in California on any pollution controlled motor vehicle. **FOR OFF ROAD USE ONLY.**

2010-2015 Camaro Chassis Components

Sport Suspension Spring Package

SLP's Sport Suspension Spring Package lowers your Camaro a full one inch all around, resulting in a lower center of gravity. The progressive spring design allows for better ride quality, quicker stopping, and faster cornering. This spring package offers incredible handling combined with an aggressive stance.

70030A Sport Suspension Package, V8, includes 4 progressive-rate springs



5-Point Subframe Connectors

Add SLP's 5-Point Subframe Connectors to your Camaro for the ultimate in bolt-on frame stiffening. These subframe connectors tie your stock front and rear subframes together (5 bolt-on contact points on each side).

70805 Subframe Connectors, Coupe (Bolt-On)

NOTE: While supplies last.



20-Inch Five-Spoke Aluminum Alloy Wheels

SLP offers distinctive 20-inch Five-Spoke Aluminum Alloy Wheels for the fifth-generation Camaro available in two different finishes:

- 1) Gray painted spokes and windows with a powder-coated heritage-style red line accent on the outer edge (#81050A)
- 2) Gray painted spokes with chrome-like windows and a powder-coated heritage-style red line accent on the outer edge (#81070A).

All have a machined face and clear-coat finish. Our light-weight 20"x8" front and 20"x9" rear wheels provide the same offset (5-1/2-inch front/6-1/4-inch rear) and width as the factory wheels and will accept the factory tires and center caps. Wheels sold while supplies last.

81050A 20-inch Five-Spoke Red-Line Wheels, Gray w/ Machined Face, Gray Windows, Set of 4

81070A 20-inch Five-Spoke Red-Line Wheels, Gray w/ Machined Face, Chrome-Like Windows, Set of 4

NOTE: While supplies last.



81070A



81050A

Braking Components

Camaro Brake Control Package

An SLP exclusive, our Camaro Brake Control Package makes it easy to heat the rear tires while minimizing wear and tear on your car's rear brake components. Designed for racing only, this kit is compatible with the factory anti-lock braking and traction control systems. Includes a waterproof electrical solenoid, activation switch, plug-in wires, CNC pre-bent steel lines with OEM-compatible fittings, mounting hardware, and detailed installation instructions. Requires brake bleeding. V8 and ZL1.

25005 Brake Control Package, V8/ZL1

020758121 Service Solenoid



Appearance Accessories

High-Lip Rear Spoiler

SLP's OE-quality composite, High-Lip Rear Spoiler features a wider, taller, more aggressive design, while still maintaining many of the design features of the stock spoiler. Easily attaches to V8 coupes using the stock bolt holes. Requires drilling holes in the decklid on V6 models not equipped with GM's RS package. Includes instructions and all necessary mounting hardware, and comes ready for prep, prime, and paint.

100041 Composite Spoiler, V6/V8 Coupe, Unpainted

NOTE: While supplies last. Does not fit 2014-2015+ models.



Front Fascia Splitter

SLP's Front Fascia Splitter adds to the already aggressive look of your Camaro and is fully functional, increasing front end downforce and stability at high speeds. Manufactured from an OEM-quality composite material, the splitter provides flexibility to help prevent cracking or breaking like most fiberglass kits. Each splitter comes complete with all mounting hardware and detailed installation instructions.

100039A Front Fascia Splitter

NOTE: Will Not Fit V6 Models. Works w/SLP's Front License Plate Bracket Assembly Part #59389. Does not fit 2014-2015+ models.



Rear Quarter Panel Graphic Kit

Rear Quarter Panel Gill Insert Graphics fade from clear to gloss black giving the quarter panels the appearance of functional vents. Includes driver and passenger side graphics. Detailed installation instructions are included.

100046A Rear Quarter Panel Graphic Kit – Gloss Black

100047A Rear Quarter Panel Graphic Kit – Flat Black



Three-Piece Rear Black-Out Panel Graphic

SLP's Three-Piece Rear Black-Out Panel Graphic comes in both gloss and flat black and is easy to apply. This feature was part of the early Camaro heritage, signifying that the car was equipped with the larger engine option. Fits V6 and V8.

100044A Rear Black-Out Panel Graphic, Gloss Black, V6/V8

NOTE: Does not fit 2014-2015+ models.



License Plate Bracket Assembly

SLP's License Plate Bracket assembly is easy to install and can be removed in seconds; simply loosen two wing nuts and your Camaro is ready for your next car show without unbolting the complete kit. It has a black powder coated finish and can be painted to match the exterior of your vehicle. Comes complete with a stylish SLP frame, all mounting hardware, and detailed installation instructions.

59389 Front License Plate Bracket Assembly, V8/ZL1

NOTE: Does not fit V6 and all models with factory ground effects.



Heritage-Style Hockey Stick Stripe Graphics

SLP's Heritage-Style Hockey Stick Stripe Graphics are a single-piece design. Available in flat black. Includes driver and passenger side graphics for the front fenders and doors. Fits V6, V8, and ZL1.

100054A Flat Black, V6/V8



SLP Logo Badge Set

SLP now offers an OE-quality chrome plated over a flexible plastic SLP logo badge. Featuring a reflective chrome red "SLP" inlay with a chrome surround, each beveled-edge badge is manufactured to the highest quality OE standards and designed to last for years. Whether your vehicle is highly-modified or you're looking for a personal yet subtle touch, SLP's chrome badge creates the look that gets your vehicle noticed. Pre-applied die-cut adhesive tape ensures an easy installation and measures 3/4-inch high x 5-3/4-inch in length to fit any car or truck. Backed by our 90-Day SLP Parts Limited Warranty and sold as a pair, this new badge is a must-have for any die-hard SLP enthusiast and makes a perfect gift without breaking the bank!

620026 SLP Logo Badge Set



Fifth-Generation Camaro Car Cover

SLP's Fifth-Generation Camaro Car Cover protects your Camaro from dust, dirt, bird "attacks", and other airborne contaminants. Silver fabric reflects sunlight and protects your car from harmful UV rays. Proudly stamped with the SLP logo and comes with a locking cable and tote bag for easy storage.

08961 Cover w/SLP Logo, 2010-2015 5th Gen. Camaro



F-BODY

1982-2002 Camaro, Camaro SS, Firebird, Firehawk



F-Body Cold Air Induction Systems

SLP pioneered these under-hood Cold Air packages for late model Camaros and Firebirds. They replace your restrictive, power robbing factory air filter assembly. By picking up cool, dense outside air and pulling it directly into the engine, these systems unlock up to 20 additional horsepower, depending on the application.

V8 Camaro/Firebird Air Box Lid

Our current V8 Camaro/Firebird Air Box Lid is an injection molded part. This process provides an OEM-quality part that's stronger than the stock lid, improves airflow, allows for an easier installation, and provides a more consistent and secure seal with the air filter.

21044 Air Box Lid, 1998-1999 V8 Camaro/Firebird

21045 Air Box Lid, 2000-2002 V8 Camaro/Firebird

210622825 Replacement Airbox Plug



21044



21045

Blackwing™ High-Flow Air Filter

Our easy-to-install Blackwing™ High-Flow Air Filter is designed to fit all 1998-2002 V6 and V8 Camaros/Firebirds and is the same filter used in our "FlowPac" air-induction systems. It is designed to fit and seal properly, while featuring improved airflow and filtering properties that are superior to the stock paper unit. Washable, dry media filter.

25010B Blackwing™ Cold Air Induction Package, 1998-2002 V6 and V8 Camaro/Firebird

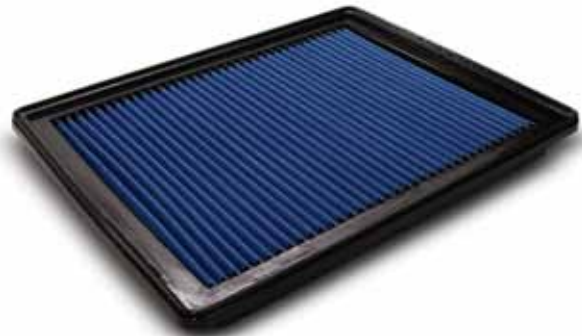

1998-2002 V6/V8 F-Body Cold Air Induction Scoop

SLP's 1998-2002 V6/V8 F-Body Cold Air Induction Scoop can unlock up to 10 additional horsepower in LS1 and 3800 V6 applications. It is constructed from high-quality 304 stainless steel for optimum durability. Use with our High-Flow Air Box Lid (#21044 or #21045), Blackwing™ Air Filter (#25012B), and F-Body Smooth Bellows (#23065) for even greater horsepower increases. Includes all necessary hardware and detailed installation instructions.

21033 Cold Air Induction Scoop, 1998-2002 V6/V8 Camaro/Firebird



1994-1997 V8 LT1 Cold Air Induction System

SLP's 1994-1997 V8 LT1 Cold Air Induction System is manufactured from stainless steel with a glossy black powder coated finish. Includes two reusable high-flow cone-style air filters and a custom "block-off plate" to isolate the filters from hot under-hood air. This system contains all necessary parts and complete installation instructions and is street legal in all 50 states. E.O. Approved. Oiled media filter.

21014 Cold Air Induction Package, Late 1994-1997 V8 Camaro/Firebird

21035B Replacement Filter (Oiled)



Blackwing™ High-Flow Reusable Air Filter

SLP's replacement Blackwing™ High-Flow Reusable Air Filter fits SLP Cold Air Induction System #21014. They're sold individually, so remember to order two! Oiled media filter.

21035B Blackwing™ Replacement Air Filter, 1994-1997 V8 for SLP Cold Air Induction Systems #21014

NOTE: #25017 filter cleaning kit is required when cleaning/re-oiling your filter.

Blackwing™ Filter Cleaner and Oil Kit

Blackwing™ Filter Cleaning and Oil Kit required for all SLP Blackwing™ oiled filters.

25017 Blackwing™ Filter Cleaner and Oil Kit



Flowpac™ Cold Air Packages

SLP's Flowpac™ Cold Air Packages combine our Cold Air Induction Scoop, High-Flow Air Box Lid, F-Body Smooth Bellows, and Blackwing® Air Filter to create an engineered package worth up to 20 horsepower over stock. Save by ordering the package!

21046	FlowPac™ Cold Air Package, 1998-1999 V8 Camaro/Firebird
21047	FlowPac™ Cold Air Package, 2000-2002 V8 Camaro/Firebird (pictured)
210622825	Replacement Air Box Plug
25010B	Replacement Air Filter



Smooth Bellows

SLP's Smooth Bellows for LS1-equipped F-Bodies replaces the restrictive accordion-style factory bellows, improving the air flow between the MAF sensor and throttle body for an increase of up to 6 horsepower. Manufactured with high-quality fiberglass-reinforced silicone.

23065 Smooth Bellows, 1998-2002 LS1 Camaro/Firebird



Close-Off Panels

Replacement Close-Off Panels for vehicles equipped with a Ram Air hoods, such as the Camaro SS, Firehawk, Ultra Z, and WS-6.

210280430	Close-Off Panel w/o holes (replacement for vehicles with Ram Air hood)
210280431	Close-Off Panel w/holes (replacement for SLP Cold Air)



F-Body Performance Components

Fan Control Switch

Another way to combat high operating temperatures is with SLP's easy-to-install Fan Control Switch. This switch allows you to turn your car's electric coolant fans on manually, yet still retain stock fan operation. So, if you're sitting in traffic or at the track waiting in the staging lanes between rounds, you can turn on your fans early to keep your engine operating cooler. Lowering your engine's operating temperature will help increase performance. All necessary hardware and instructions for an easy, plug-in installation are included.

63011 Fan Control Switch, 1993-2002 V6/V8 Camaro/Firebird



Skip-Shift Eliminator

Decide for yourself what gear you want to be in! Dump that annoying first-to-fourth “skip-shift” that GM incorporates into every 6-speed with SLP’s Skip-Shift Eliminator. This plug-in piece requires no additional modification to your vehicle. With it in place, you take complete control over gear selection. Easy installation instructions.

21008 1994-2002 Camaro and Firebird

NOTE: Not legal for sale or use in California on any pollution controlled motor vehicle. **FOR OFF-ROAD USE ONLY.**



LT1/TPI Throttle Body Flow Booster

SLP’s LT1/TPI Throttle Body Flow Booster improves airflow by 30 CFM at the entrance of your throttle body. This airfoil-shaped piece smooths out the airflow into the throttle body and adds up to 7 additional horsepower. The flow booster is manufactured from aircraft-quality, cast aluminum and includes all installation hardware and instructions for easy, bolt-on installation. For maximum benefit, use with an SLP Cold Air package. E.O. Approved.

22100 Throttle Body Flow Booster, 1985-1997 LT1/TPI



Lower-Temperature Thermostats

Reduces coolant temperature, easy to install, and requires no additional modifications. SLP’s 160-degree Lower Temperature Thermostats are a cost effective way to improve your car’s performance.

100223 160° Thermostat, LS1 1998-2002 Camaro/ Firebird

100224 160° Thermostat, 1992-1997 LT1 Camaro/Firebird



1998-2002 F-Body PowerFlo™ Long-Tube Headers

Stainless Steel Long-Tube Headers

Widely copied but never equaled, SLP’s 1998-2002 F-Body PowerFlo™ Stainless Steel Long-Tube Headers are designed to optimize exhaust scavenging for phenomenal power increases. Gains of up to 30 horsepower and 30 lb-ft of torque are possible, depending on your application.

SLP F-Body PowerFlo™ Long-Tube F-Body Headers Feature:

- 1-3/4-inch polished ceramic coated 409 stainless steel, one-piece mandrel bent long tubes
- New high-flow collectors for more horsepower and torque in the mid to upper RPM range
- Header allows for up to two inches more ground clearance than other designs
- Metallic substrate 200 cell/inch high-flow cats included
- New 3-inch high-flow SS Y-pipe designed for unrestricted flow
- Bolts to factory cat-back or SLP cat-back
- “Drop-in” design; no engine or transmission movement needed for installation
- No rewiring needed for installation
- All clamps, hardware, extensions, and instructions are included



30046 Long-Tube Header Package, 1998-1999 LS1 Camaro/ Firebird, includes Y-pipe, High-Flow Cats, Installation Kit

30047 Long-Tube Header Package, 2000 LS1 Camaro/Firebird, includes Y-pipe, High-Flow Cats, Installation Kit

30048 Long-Tube Header Package, 2001-2002 LS1 Camaro/ Firebird, includes Y-pipe, High-Flow Cats, Installation Kit

NOTE: Not legal for sale or use in California on any pollution controlled motor vehicle. **FOR OFF ROAD USE ONLY.**

Spark Plug Socket

SLP's specially-designed Spark Plug Socket makes spark plug removal in the crowded F-body engine compartment much easier. These high-quality 5/8-inch sockets are made exclusively to SLP's standards.



30102 Spark Plug Socket, modified to work with headers

1993-2002 F-Body Exhaust Systems and Components

LoudMouth™ or LoudMouth II™ Catalyst-Back Exhaust Systems

SLP's Loud Mouth™ and Loud Mouth II™ Catalyst-Back Exhaust Systems for your 1998-2002 LS1-powered Camaro or Firebird replace all the pipes from the Y-pipe back, with new mandrel-bent stainless steel tubing for higher flow along with an SLP bullet-style resonator or muffler. These exhaust systems provide up to a 25 horsepower gain and are a direct bolt-on replacement for the stock exhaust system.



31042	LoudMouth™ Exhaust System w/2.5-inch Dual/Dual Tips
31042A	LoudMouth™ Exhaust System w/3.5-inch Single-Wall Tips
31043	LoudMouth II™ Exhaust System w/2.5-inch Dual/Dual Tips
31043A	LoudMouth II™ Exhaust System w/3.5-inch Single-Wall Tips
31044	LoudMouth™ Exhaust System w/4-inch Dual-Wall Tips
31045	LoudMouth II™ Exhaust System w/4-inch Dual-Wall Tips

NOTE: All exhaust systems can be installed on 1993-1997 LT1 Camaro/Firebirds with the use of SLP #30044 or #30045 installation kits.

LoudMouth III™ Exhaust System

SLP's 1998-2002 Camaro or Firebird LoudMouth III™ Exhaust System offers up to a 20 horsepower gain. The system includes a pair of our PowerFlo™ mufflers and one of our LoudMouth II™ bullet-style mufflers, which utilize a straight-through design and ceramic-wrapped perforated core to significantly outflow traditional chambered and turbo-type mufflers. Available with three different polished tip styles (shown at left).



31083	LoudMouth III™ Exhaust System w/2.5-inch Dual/Dual Tips
31084	LoudMouth III™ Exhaust System w/4-inch Dual-Wall Tips
31085	LoudMouth III™ Exhaust System w/3.5-inch Slash-Cut Tips

LoudMouth™ Conversion Kit

Is your LoudMouth™ too Loud? Upgrade your existing SLP Loud Mouth™ exhaust system with these easy-to-install Loud Mouth™ Conversion Kits. These assemblies come complete with all necessary mufflers, pipes, hardware, and detailed installation instructions.

31086	LoudMouth III™ Muffler Conversion Kit
31067	LoudMouth II™ Bullet Conversion Kit



NOTE: Reuse your existing tips.

Larger Diameter Y-Pipe

SLP's LoudMouth™ Larger Diameter Y-Pipe assembly for 1998-2002 Camaros/Firebirds with V8 engines is designed to replace the "flat" factory pipe (behind the stock catalytic converters) and bolts to your stock exhaust manifolds. The higher-flowing bends will increase the efficiency of your exhaust system and provide up to 10 additional horsepower, depending on the application. Comes complete with installation hardware and instructions.

31035 Larger Diameter Replacement Y-Pipe, 1998-2002 LS1 Camaro/Firebird

NOTE: 1998-1999 models requires additional modifications.



Driveline Components

Underdrive Pulley/Harmonic Balancer

SLP's Underdrive Pulley/Harmonic Balancer reduces accessory drive speed by 25%, increasing your engines power output up to by 5 horsepower. This balancer/pulley for the LS1 engine incorporates a pair of extra-tall belt retention walls that eliminate the belt slippage issues common with other LS balancers. Features 100% steel construction, integral timing marks, and built-in puller-mounting threads. Includes a new balancer mounting bolt and detailed installation instructions.

100221 Underdrive Pulley/Harmonic Balancer, 1998-2002 LS1 Camaro/Firebird

NOTE: New belts are required for each application. Please contact SLP for proper belt part numbers.



Suspension Components

Performance Suspension System

If you're looking to improve the handling of your stock Camaro or Firebird, SLP offers a Performance Suspension System that provides world-class handling, without the harshness usually associated with a suspension package of this caliber. This system is the same as the optional suspension system that was originally available on all Camaro SS and Firehawk models, and includes specially-calibrated springs and shocks. Custom-wound SLP springs provide your Camaro/Camaro SS or Firebird/Firehawk with better handling and control. They lower your car up to 1-inch from stock and provide a firm, stable base for aggressive street driving or road racing. Custom Bilstein shocks are built to our specifications for use in road racing applications. The ultimate in a non-adjustable dual-purpose shocks.

70002	Shocks/Springs, Front/Rear, 1993-2002 Camaro/Firebird (set)
70008	Shock Package Only, 1993-2002 Camaro/Firebird (set of 4)
70009	Spring Package Only, 1993-2002 Camaro/Firebird (set of 4)
720782798	Front Level II Replacement Spring, 1996-2000 Camaro SS/Firehawk/Comp T/A (ea.)
720783798	Rear Level II Replacement Spring, 1996-2000 Camaro SS/Firehawk/Comp T/A (ea.)
10578	Bilstein Front Level II Replacement Shock, 1996-2000 Camaro SS/Firehawk/Comp T/A (ea.)
10579	Bilstein Rear Level II Replacement Shock, 1996-2000 Camaro SS/Firehawk/Comp T/A (ea.)



Subframe Connectors

SLP's Subframe Connectors fit all 1993-2002 V6 and V8 Camaros and Firebirds (except convertible models). Designed to tie your car's front and rear subframes together, the additional cross bracing increases chassis stiffness dramatically. Connectors are constructed of heavy-duty steel box tubing and will significantly increase your car's performance and handling capabilities. By reducing chassis flex, annoying T-top and dash rattles are minimized. Cars used in drag racing and autocross are susceptible to flex creases and similar damage that can be prevented by installing these Subframe Connectors. SLP's subframe connectors are available in two versions. Bolt-on connectors are powder coated black and are an easy install using existing mounting points. The weld-in design comes unfinished and must be painted after installation.

70801 Subframe Connectors, 1993-2002 Camaro/Firebird Coupe (Bolt-On)

70802 Subframe Connectors, 1993-2002 Camaro/Firebird Coupe (Weld-On)



Strut Tower Brace

Our Strut Tower Brace is designed to fit 1993-2002 V8 Camaros and Firebirds. It's easy to bolt on and will increase chassis rigidity, which improves the overall handling of your vehicle.

70005 Strut Tower Brace, 1993-2002 Camaro/Firebird V8 and 1998-2002 Camaro SS

NOTE: Does not fit 1996-1997 Camaro SS.



Embossed SLP logo on each Strut Tower Brace means Guaranteed Performance!

Braking Components

F-Body Brake Control Packages

SLP's F-Body Brake Control Packages are specifically designed for all 1987-2002 V8 and V6-powered GM F-bodies. Designed for racing only, this kit makes it easy to heat the rear tires while minimizing wear and tear on your rear brake components. These packages are compatible with the factory anti-lock braking and traction control systems. They include a waterproof electrical solenoid, an activation switch, plug-in wires, CNC-bent steel lines with OEM-compatible fittings, mounting hardware, and detailed installation instructions. (Brake bleeding required).

25000 Brake Control Package, 1998-2002 Camaro/Firebird

24049 Brake Control Package, 1993-1997 Camaro/Firebird

24048 Brake Control Package, 1987-1992 Camaro/Firebird

24049

25000



24048



020758121 Service Solenoid

Appearance Accessories

License Plate Bracket

SLP's License Plate Bracket allows you to mount a front license plate to your 1993-2002 Camaro without hindering the look of the grille. It is manufactured of rustproof aluminum and is easy to install. Can also be painted to match the color of your car. Includes mounting hardware and detailed installation instructions.

59388 License Plate Bracket, 1993-2002 Camaro

NOTE: License plate laws vary by state. For front end use only where allowed by law.



Camaro SS Replacement Grille

The Camaro SS Replacement Grille fits 1998-2002 models. Each grille includes a new GM-supplied Bowtie emblem or SS emblem, along with all hardware and installation instructions.

10668R	10668R Grille Assembly, 1998-2002 Camaro SS, Black with Red Trim
10668S	Grille Assembly, 1998-2002 Camaro SS, Black with Silver Trim

NOTE: For states that require a front license plate, SLP recommends our License Plate Bracket (#59388) for use with these replacement grilles.

SS

10668S

10668R



Interior Accessories

Front Floor Mats and Rear Deck Mats

These premium quality, heavy-duty, custom-fitted front floor mats and rear deck mats are embroidered with the Camaro SS, 35th Anniversary Camaro SS, or SLP emblems. The deck mats enhance the appearance of the shelf area behind the rear seat in a Camaro or Firebird Coupe. Available in ebony, dark gray, and neutral, these floor mats and deck mats provide the finishing touch to your fourth-generation F-Body.

10446	Floor Mat Set, Ebony, Camaro SS, Coupe (shown)
10447	Floor Mat Set, Ebony, Camaro SS, Convertible
40195	Floor Mat Set, Dark Gray, Camaro SS, Coupe
40200	Floor Mat Set, Dark Gray, Camaro SS, Convertible
10951	Floor Mat Set, Ebony, Camaro SS 35th Anniversary, Coupe (shown)
10952	Floor Mat Set, Ebony, Camaro SS 35th Anniversary, Convertible
44000	Floor Mat Set, Front, Ebony w/color-embroidered SLP logo
44001	Floor Mat Set, Front, Dark Gray w/color-embroidered SLP logo
10842	Deck Mat, Ebony, Camaro SS (shown)
10881	Deck Mat, Dark Gray, Camaro SS
10953	Deck Mat, Ebony, 2002 Camaro SS 35th Anniversary



Leather-Wrapped Shift Knobs

Leather-wrapped shift knobs for 1984-2002 5-speed and 6-speed F-bodies. Embossed with the SLP logo or "H" logo.

60081	Shift Knob, 1984-2002 5/6-Speed Shifter, Leather-Wrapped with "H" embossed logo, Black
10416	Shift Knob, 1984-2002 5/6-Speed Shifter, Leather-Wrapped with SLP embossed logo, Black



60081



10416

F-Body Car Covers

SLP's F-Body Car Covers protect your Camaro or Firebird from dust, dirt, bird "attacks", and other airborne contaminants. Silver fabric reflects sunlight and protects it from harmful UV rays. Proudly stamped with the SLP logo and comes with a locking cable and tote bag for easy storage.

08960	Cover with SLP Logo, 1993-2002 Camaro/Firebird
--------------	--



CORVETTE

1985-2015 C4-C6, Z06 Grand Sport, ZR1



C4/C5/C6/Z06 Cold-Air Induction Systems

SLP's Blackwing™ C5/C6/C7/Z06 Cold-Air Induction Systems use a wire-reinforced, reusable, and washable blue filter material that requires re-oiling after washing for maximum filtration. They also feature an exclusive airflow restriction indicator that changes color (red) when cleaning is required.

C5 "FlowPac™" Cold Air Induction Package

C5 "FlowPac™" Cold Air Induction Package combines our Blackwing™ Cold Air Induction System and C5 Smooth Bellows to create an engineered package worth up to 23 additional horsepower over stock. It also fits all 2001-2004 Z06 models!

21110E	Blackwing™ Cold Air Induction System, Early Filter Assy. (#23066 not included) 1997-2000 C5
21110L	Blackwing™ Cold Air Induction System, Late Filter Assy. (#23066 not included, #21111 Bellows Kit included) 2001-2004 C5
21114E	FlowPac™ Cold Air Induction Early Package, includes #21110E and #23066, 1997-2000 C5
21114L	FlowPac™ Cold Air Induction Late Package, includes #21110L and #23066, 2001-2004 C5



C6 Blackwing™ Cold Induction Systems

One of the quickest and easiest ways to improve the performance of your C5/C6/Z06 Corvette is to replace the restrictive factory air filter assembly with SLP's easy-to-install Blackwing™ Cold Air Induction System. These systems offer easy, bolt-on installation and require no vehicle modification. All necessary hardware and installation instructions are included.

C6/Z06 Blackwing™ System

C6/Z06 Blackwing™ System for the 2008-2013 LS3 C6 and 2006-2013 LS7 Z06 features an integrated MAF housing, increased air bridge volume, secure mounting points and our exclusive Blackwing™ air filter. This LS3/LS7 Blackwing™ System is good for up to 10 horsepower and 11 lb-ft gain at the flywheel.

21121	Blackwing™ Cold Air Induction, 2008-2013 C6 Corvette/ 2010-2013 Grand Sport/2006-2013 Z06
200326001	Replacement Oiled Media Filter

NOTE: Blackwing™ Filter Cleaner and Oil Kit #25017 is required when cleaning/re-oiling your filter.

C6 Blackwing™ System

C6 Blackwing™ System for the 2005-2007 C6 boasts the same great features found on the system above and includes a high-volume air bridge.

21115	Blackwing™ Cold Air Induction System, 2005-2007 C6
200326002	Replacement Oiled Media Filter

NOTE: Blackwing™ Filter Cleaner and Oil Kit #25017 is required when cleaning/re-oiling your filter.

Blackwing™ Filter Cleaner and Oil Kit

Blackwing™ Filter Cleaning and Oil Kit required for all SLP Blackwing™ oiled filters.

25017	Blackwing™ Filter Cleaner and Oil Kit
--------------	---------------------------------------



C5 Smooth Bellows

C5 Smooth Bellows replace the restrictive accordion-style factory bellows, straightening airflow between the inlet duct and throttle body for an increase of up to 5 horsepower. Constructed of high-quality, fiberglass-reinforced silicone and includes a 5-inch worm-drive clamp and complete installation instructions.

23066 Smooth Bellows, 1997-2004 C5

NOTE: On 1997 and 1998 models, it is necessary to drill a 1/8-inch hole in the bellows to accommodate the factory fuel pressure-regulator barb.

C5 Bellows Kit

This easy-to-install C5 Bellows Kit allows our Blackwing™ filter (#21110) to fit 2001-2004 C5 Corvette including the ZO6. Detailed instructions are included.

21111 Blackwing™ Bellows Kit, 2001-2004 C5



C4 Replacement High-Flow Air Filter

Use the 1985-1989 C4 Replacement High-Flow Air Filter with SLP's Cold Air Induction System #21050. Also replaces the stock filter in 1985-1989 C4 Corvettes. Washable, dry media filter.

25010B High-Flow Replacement Air Filter, 1985-1989 C4



TPI C4 Cold Air Induction System

SLP's TPI C4 Cold Air Induction System for 1985-1989 TPI equipped C4 Corvettes picks up cold, dense outside air from the high-pressure area in front of your radiator and feeds it to your engine. This cool airflow will unlock up to 20 additional horsepower. This system, along with all SLP Blackwing™ systems, carry our performance guarantee, to outperform any other cold air system available for your Corvette, and is legal for street use in all 50 states. Constructed of OEM-quality polypropylene, the kit includes a reusable high-flow air filter, as well as all necessary hardware, complete instructions for an easy bolt-on installation, and will last the life of your vehicle. Washable dry media filter.

21050 Cold-Air Induction Package, 1985-1989 C4

21050F Replacement High-Flow Replacement Air Filter

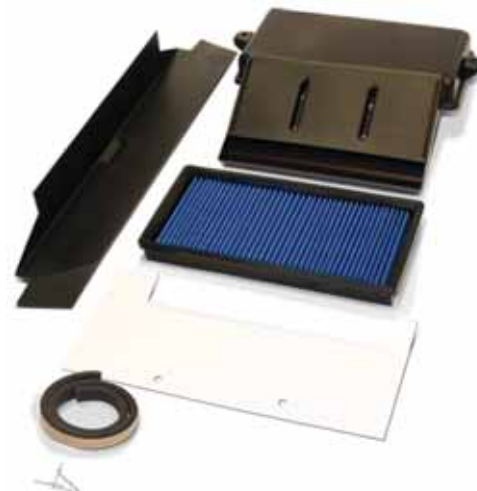

Cold Air Induction Packages

This under-hood Cold Air Induction Package for 1992-1996 LT1/LT4 C4 Corvettes and 1990-1995 ZR1s will provide up to 20 additional horsepower depending on your application. The kit is constructed from stainless steel tubing that is black powder coated for an OE appearance. It includes three reusable, high-flow, cone-type air filters, all necessary hardware, and instructions for an easy bolt-on installation. Air system uses oiled media filters.

21028 Cold Air Induction Package, 1992-1996 LT1/LT4, 1990-1995 ZR1

210326200B Replacement Oiled Media Filter



Performance Components

LT1/TPI Throttle Body Flow Booster

SLP's LT1/TPI Throttle Body Flow Booster improves airflow by 30 CFM at the entrance of your throttle body. This airfoil-shaped piece smooths out the airflow into the throttle body and adds up to 7 additional horsepower. The Flow Booster is manufactured from aircraft-quality cast aluminum and includes all installation hardware and instructions for easy bolt-on installation. For maximum benefit, add an SLP Cold Air package. E.O. approved.

22100 Throttle Body Flow Booster, 1985-1997 LT1/TPI



Underdrive Pulley/Harmonic Balancer

SLP's Underdrive Pulley/Harmonic Balancer reduces accessory drive speed by 25%, increasing your engine's power output by up to 5 horsepower. This balancer/pulley for LS1/LS6/LS2/LS3 engines incorporates a pair of extra-tall belt retention walls that eliminate the belt slippage issues common with other LS balancers. 100% steel construction, integral timing marks, and built-in puller-mounting threads. Includes a new balancer mounting bolt and detailed installation instructions.

100225 Underdrive Pulley/Harmonic Balancer, 1997-2013 LS1/LS6/LS2/LS3 (C6 only)

NOTE: New belts are required for each application. Please contact SLP for proper belt part numbers.



Skip-Shift Eliminator

Decide for yourself what gear you want to be in! Dump that annoying first-to-fourth "skip-shift" that GM incorporates into every 6-speed with SLP's Skip-Shift Eliminator. This plug-in piece requires no additional modification to your vehicle. With it in place, you take complete control over gear selection. Easy installation instructions.

21008 Skip-Shift Eliminator, 1997-2013 Corvette with 6 speed manual transmission

NOTE: Not legal for sale or use in California on any pollution-controlled motor vehicle. **FOR OFF-ROAD USE ONLY.**



Lower-Temperature Thermostats

Reduces coolant temperature, easy to install, and requires no additional modification. SLP 160-degree Lower Temperature Thermostats are a cost-effective way to improve your car's performance.

100223 160° Thermostat, LS1 1997-2003 Corvette

100224 160° Thermostat, 1992-1996 LT1 Corvette

100228 160° Thermostat, 2004-2008 LS1/LS6/LS2/LS3/LS7 Corvette

100229 160° Thermostat, 2009-2013 LS3/LS7 Corvette



100223



100224



100228

C6 Header Packages

Maximize the power of your C6 Corvette with our Long-Tube Header packages. Our engineers designed them for the greatest horsepower gain possible from the factory engine.

SLP's 2005-2013 C6 Long-Tube Header Packages add up to 25 horsepower and 25 lb-ft. of torque over the stock system. They feature 1-3/4-inch primary tubes flowing into two 2-1/2-inch high-flow venturi-style collectors. The headers are built from mandrel-bent 409 stainless steel and are ceramic coated to keep heat in, exhaust velocity up, and under-hood temperatures down. The rest of the system is made from high-quality 304 polished stainless steel. Included in each package is a pair of 3-inch high-flow catalytic converters which flow into a 2-1/2-inch integrated LoudMouth™ X-pipe. These packages are compatible with all stock emission-control equipment and use OEM flanges for a perfect fit and proper bolt retention. All necessary hardware and installation instructions are included. Backed by our Limited Lifetime Warranty.

30124 Header Package, 2005-2008 C6 Includes Installation Kit/High-Flow Cats/2-1/2-inch dia. LoudMouth™ X-Pipe

30127 Header Package, 2009-2013 C6 Includes Installation Kit/ High-Flow Cats/2-1/2-inch dia., LoudMouth™ X-Pipe

NOTE: ALL SLP Long-Tube Headers and components listed in this section are not legal for sale or use in California on pollution-controlled motor vehicles. **FOR OFF-ROAD USE ONLY.**

Spark Plug Socket

SLP's specially designed Spark Plug Socket makes spark plug removal in the Corvette engine compartment much easier. We have these high-quality 5/8-inch sockets made exclusively to SLP's standards.

30102 Spark Plug Socket, modified to work with headers



Long-Tube Header Features:

- Compatible with all factory emission equipment
- 2-1/2-inch venturi-style 4-into-1 collectors
- Easy, bolt-on installation
- Stainless steel .055-inch wall thickness tubing for long life
- Mandrel bent to maximize exhaust flow
- Coated with aluminum-ceramic thermal barrier coating to keep heat in, exhaust gas velocity up, and underhood temperatures down
- SLP's Performance Guarantee and Limited Lifetime Warranty



Crossover Assemblies

SLP's LoudMouth™ X-Pipe, Downpipes and Balance Tube Assemblies are precision-bent on CNC bending equipment from 2-1/2-inch diameter 304 stainless steel, then carefully hand-crafted for a perfect fit. At both ends, we provide an OEM-style Torca notch and include OEM-style Torca clamps for a perfect seal. This ensures a better seal and makes installation and removal easy.

NOTE: LoudMouth™ X-Pipe and Balance Tube Assemblies are NOT designed to work with other headers or stock exhaust.

LoudMouth™ X-Pipe Crossover Features:

- Designed to maximize performance of SLP headers
- Easy bolt-on installation
- 304 stainless steel 3-inch or 2-1/2-inch diameter tubing
- Mandrel-bent to maximize flow
- SLP's Performance Guarantee and Limited Lifetime Warranty

Downpipes Feature:

- Designed to maximize performance of SLP headers
- Easy, bolt-on installation
- 2-1/2-inch diameter 304 stainless steel for long life
- SLP's Performance Guarantee and Limited Lifetime Warranty

SLP's High-Flow Catalytic Converters are designed specifically to maximize the performance of our headers and our Corvette exhaust systems, not for stock replacement.

High-Flow Catalytic Converters Feature:

- Designed to maximize performance of SLP headers and exhaust systems
- Easy bolt-on installation
- SLP's Performance Guarantee and Limited Lifetime Warranty

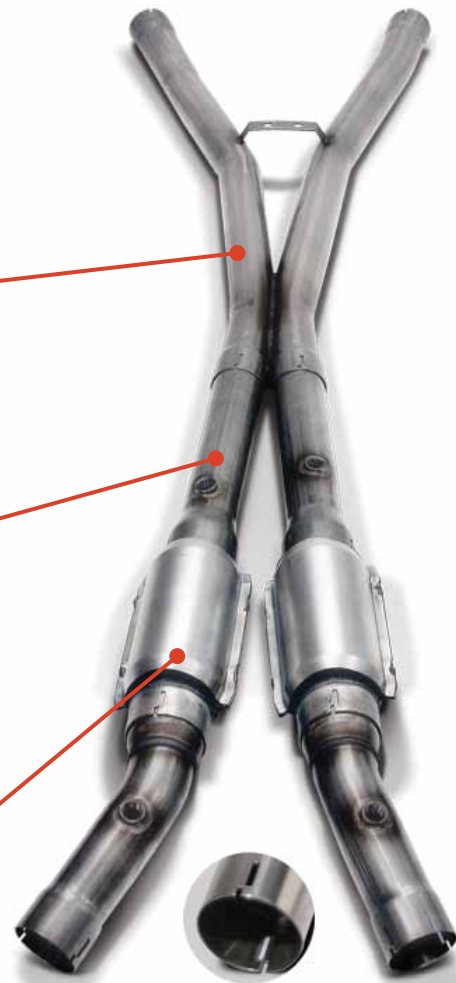

OEM-Style Torca Notch

C6 Exhaust Systems

For more horsepower and a real muscle car sound, bolt on a LoudMouth™ or LoudMouth II™ catalyst-back C6 exhaust system. These stainless steel systems provide up to a 15 horsepower gain and are direct bolt-on replacements for the stock exhaust system.

Our LoudMouth II™ system provides a rich and powerful sound with a muscular tone. For an even more aggressive exhaust note, you'll want our LoudMouth™ system that will let everyone know you're coming! SLP's unique modular technology makes it possible on both the LoudMouth™ and LoudMouth II™ systems to switch between mufflers and resonators in a matter of minutes. These exhaust systems provide up to a 15 horsepower gain, are handcrafted from 2-1/2-inch 304 stainless steel and include detailed installation instructions.

NOTE: Exhausts do not fit Z06 or ZR1.

31077	LoudMouth™ Exhaust System with Dual Split Round Tips, 2005-2008 C6/Grand Sport
31078	LoudMouth II™ Exhaust System with Dual Split Round Tips, 2005-2008 C6/Grand Sport
32000	LoudMouth™ Exhaust System with Dual Split Round Tips, 2009-2013 C6/Grand Sport
32001	LoudMouth II™ Exhaust System with Dual Split Round Tips, 2009-2013 C6/Grand Sport



C6 LoudMouth™ and LoudMouth II™ Exhaust Systems Feature:

- Limited Lifetime Warranty
- Up to a 15 horsepower gain
- Handcrafted from 304 stainless
- Modular design
- Easy bolt-on installation using OEM band clamps
- Polished 3-1/2-inch dual split round tips or cast aluminum tips

31062	LoudMouth™ Bullet-Style Resonators only (pair) 2005-2013 C6
31063	LoudMouth II™ Bullet-Style Mufflers only (pair) 2005-2013 C6



LoudMouth III™ Catalyst-Back Exhaust Systems

SLP's LoudMouth III™ Catalyst-Back Exhaust Systems were developed to sound great, outside, while retaining a comfortable interior volume. Both of these systems provide up to an 11 horsepower gain and are louder than stock. They're available with polished 3-1/2-inch dual split round tips, or a distinctive cast aluminum quad tips with a black satin finish, each providing you with a very distinctive look and sound. All systems feature handcrafted 2-1/2-inch 304 stainless steel, a fully polished muffler with a stamped SLP logo, and are covered by our Limited Lifetime Warranty. Detailed installation instructions are included.

C6 LoudMouth III™ Exhaust Systems Feature:

- Limited Lifetime Warranty
- Up to an 11 horsepower gain
- Handcrafted from 304 stainless steel
- Easy bolt-on installation
- Polished 3-1/2-inch dual split round tips or cast aluminum quad tips

31079	LoudMouth III Exhaust System with Dual Split Round Tips, 2005-2008 C6/Grand Sport
32003	LoudMouth III Exhaust System with Dual Split Round Tips, 2009-2013 C6/Grand Sport



NOTE: Exhausts do not fit Z06 or ZR1.

C5 Exhaust System

LoudMouth™ Stainless Steel Exhaust System

SLP also offers a LoudMouth™ Stainless Steel Exhaust System for the C5 Corvette with a much more muscular sound. This exhaust system provides up to a 15 horsepower gain and weighs approximately 20 lbs less than the stock system, since it uses no mufflers. It is a bolt-on replacement for the original system, and is manufactured from mandrel-bent 304 stainless steel, with 2-1/2-inch over-axle pipes and 2-1/4-inch tail pipes with 4-inch polished exhaust tips. It features easy bolt-on installation and includes all necessary hardware and detailed instructions.

C5 PowerFlo™ Exhaust System Features:

- Limited Lifetime Warranty
- Up to 15 horsepower gain
- Hand-crafted from 304 stainless
- Easy, bolt-on installation

31049	LoudMouth Exhaust System, 1997-2004 C5
--------------	--

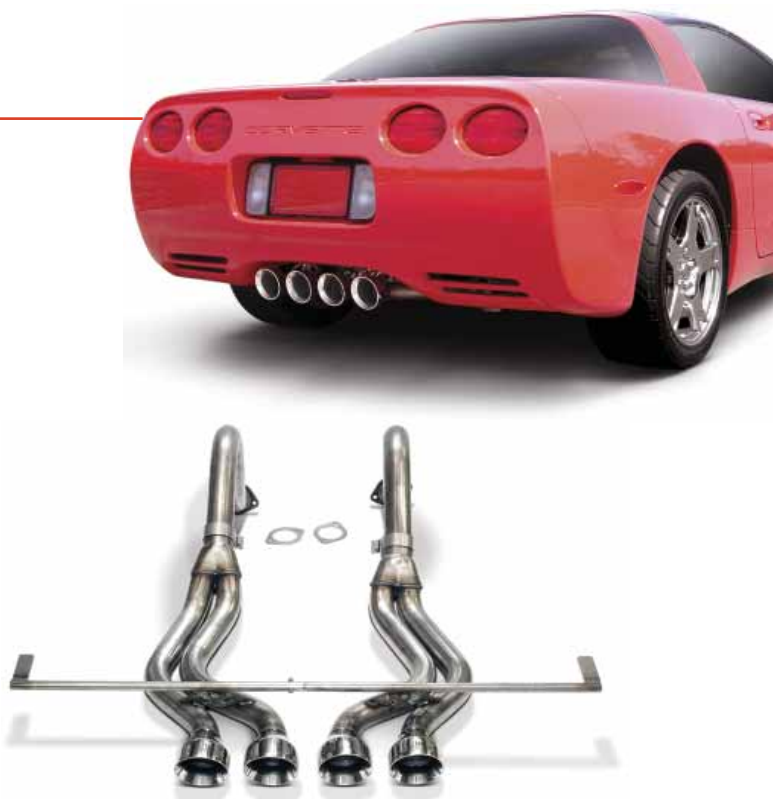

Driveline Components

LS9/ZR1 Dual Clutch and Flywheel Package

SLP's fully-balanced LS9/ZR1 Dual Clutch and Flywheel Package was designed as a bolt-on replacement clutch assembly for your 2005-2013 C6, Z06, or Grand Sport. It includes the GM ZR1 Corvette Twin Disc Clutch/Pressure Plate Assembly, SLP's new 6-bolt flange, steel billet flywheel, and a new slave cylinder spacer. All hardware and installation instructions are included.

60021A Clutch Package, 2005-2013 C6, Z06, and Grand Sport (no spacers)



C5 and C6 Appearance Accessories

C6 Rear Spoiler

SLP's C6 Rear Spoiler for 2005-2013 C6 or Z06 Corvettes is easily installed and really enhances the appearance of your Corvette's rear. The C6 Rear Spoiler is made from composite material that is unaffected by temperature and comes ready for prep, prime, and paint. All necessary installation components, 3M adhesive, and instructions are included. No drilling required.

100100 Rear Spoiler, 2005-2013 C6, unpainted



C5 Rear Spoiler

SLP's one-piece Rear Spoiler provides a subtle but elegant upgrade to the rear of your C5. Unlike rigid fiberglass aftermarket spoilers, ours is manufactured from OEM-quality composite material, the same flexible material that GM uses to manufacture front and rear C5 fascias. Each spoiler comes ready for prep, prime, and paint. All necessary installation components, 3M adhesive, and instructions are included. No drilling required.

100101 Rear Spoiler, 1997-2004 C5, unpainted



Interior Accessories

Supercharger Custom Boost Gauge Pod

SLP's exclusive Supercharger Custom Boost Gauge Pod is designed for use on all 2005-2013 C6 Corvettes equipped with an SLP or other TVS 2300 Supercharger Package.

90540A Gauge Pod Only

90541A Boost Gauge Only

90542A Boost Gauge and Gauge Pod



G8

2008-2009-1/2 GT/GXP



2008-2009 G8 Performance Components

Underdrive Pulley/Harmonic Balancer

SLP's Underdrive Pulley/Harmonic Balancer reduces accessory drive speed by 25%, increasing your engine's power output by up to 5 horsepower. This balancer/pulley for L76 G8-GT and LS3 GXP engines incorporates a pair of extra-tall belt retention walls that eliminate the belt slippage issues common with other LS balancers. Features 100% steel construction, integral timing marks, and built-in pulley-mounting threads. Includes a new balancer mounting bolt and detailed installation instructions.

100225 2008-2009 L76 G8-GT, LS3 GXP

NOTE: New belts are required for each application. Please contact SLP for proper belt part numbers.



160° Lower-Temperature Thermostats

Reduces coolant temperature, easy to install, and requires no additional modification. SLP 160-degree Lower Temperature Thermostats are a cost-effective way to improve the performance of your G8-GT and GXP.

100228 2008-2009 Early G8-GT

100229 2009-1/2 G8-GT, GXP



Skip-Shift Eliminator

Decide for yourself what gear you want to be in! Dump that annoying first-to-fourth "skip-shift" GM incorporates into every 6-speed with SLP's Skip-Shift Eliminator. This plug-in piece requires no additional modification to your vehicle. With it in place, you take complete control over gear selection. Includes easy installation instructions.

21008 2009 Pontiac G8 GXP

NOTE: Not legal for sale or use in California on any pollution-controlled motor vehicle. FOR OFF-ROAD USE ONLY.



Long-Tube Headers

G8 Long-Tube Headers

SLP's PowerFlo™ G8 Long-Tube Headers provide gains of up to a 28 horsepower and 29 lb-ft of torque. Includes 1-3/4-inch primaries, 3-inch collectors, and high-flow catalytic converters that bolt to the stock catalyst-back exhaust system or any of SLP's axle-back systems. Headers are aluminum and ceramic coated inside and out. Includes all necessary hardware and installation instructions. Backed by our Limited Lifetime Warranty.

30210 2008-2009 G8-GT, GXP, use w/stock exhaust system

NOTE: Not legal for sale or use in California on pollution-controlled motor vehicles. FOR OFF-ROAD USE ONLY.



Axle-Back Exhaust Systems

LoudMouth III™ or LoudMouth™ Axle-Back Exhaust Systems

SLP's LoudMouth III™ or LoudMouth™ Axle-Back Exhaust Systems were designed and tuned specifically for the G8-GT and GXP. Our LoudMouth™ system produces a deep rich sound. The polished stainless steel mufflers provide a perfect blend of muscle car and Grand Touring sound quality. The LoudMouth™ system eliminates the use of mufflers entirely, resulting in a significantly more muscular and powerful sound. Both systems feature mandrel-bent stainless steel pipes outfitted with uniquely-shaped 304 steel exhaust tips that fit the factory stainless steel pipes. Includes all hardware and detailed installation instructions.

31190	LoudMouth III™ Axle-Back Exhaust System, 2008-2009 G8-GT, GXP
--------------	---

31191	LoudMouth™ Axle-Back Exhaust System, 2008-2009 G8-GT, GXP
--------------	---



GTO

2004-2006



Performance Components

Underdrive Pulley/Harmonic Balancer

SLP's Underdrive Pulley/Harmonic Balancer reduces accessory drive speed by 25%, increasing your engine's power output by up to 5 horsepower. This pulley/balancer incorporates a pair of extra-tall belt retention walls that eliminate the belt slippage issues common with other LS balancers.

100226 2004-2006 LS1/LS2 GTO

NOTE: New belts are required for each application. Please contact SLP for proper belt part numbers.



Skip-Shift Eliminator

Decide for yourself what gear you want to be in! Dump that annoying first-to-fourth "skip-shift" that GM incorporates into every 6-speed with SLP's Skip-Shift Eliminator. This plug-in device requires no additional modifications to your vehicle. With it in place, you take complete control over gear selection. Includes easy installation instructions.

21008 2004-2006 GTO with Manual Transmissions

NOTE: Not legal for sale or use in California on any pollution-controlled motor vehicle. **FOR OFF-ROAD USE ONLY.**



Long-Tube Headers

2004-2006 GTO PowerFlo™ Long-Tube Stainless Steel Headers

Bolt on these 2004-2006 GTO PowerFlo™ Long-Tube Stainless Steel Headers for a noticeable improvement in horsepower and torque. These headers maximize power throughout the entire rpm range with 1-3/4-inch primaries flowing into 3-inch collectors and downpipes, then into our High-Flow Catalytic Converters. Use our LoudMouth™ (#31560) or LoudMouth II™ (#31561) Catalyst-Back Exhaust with integrated LoudMouth™ X-Pipe crossover for the most power and best sound possible from this exhaust system. Headers are ceramic coated to cut down on heat transfer, increase exhaust gas velocity, and reduce underhood temperatures. All necessary hardware, gaskets, clamps, and instructions are included for installation.

30164 1-3/4-inch Long-Tube, Coated Headers with High-Flow Cats/Downpipes, 2004 GTO

30168 1-3/4-inch Long-Tube, Coated Headers with High-Flow Cats/Downpipes, 2005-2006 GTO

NOTE: Not legal for sale or use in California on pollution-controlled motor vehicles. **FOR OFF-ROAD USE ONLY.**



30168



30164

Spark Plug Socket

SLP's specially designed Spark Plug Socket makes spark plug removal in the GTO engine compartment much easier. We have these high-quality 5/8-inch sockets made exclusively to SLP's standards.

30102 Spark Plug Socket, modified to work with headers



Exhaust Systems

2005-2006 GTO LoudMouth™ and LoudMouth II™ Catalyst-Back Exhaust Systems

SLP's 2005-2006 GTO LoudMouth™ and LoudMouth II™ Catalyst-Back Exhaust Systems provide additional horsepower and torque with an aggressive muscle car rumble. The key to the systems' distinctive sound is a pair of stainless steel LoudMouth™ resonators or LoudMouth II™ bullet-style mufflers. The additional performance comes from the free-flow design and our built-in LoudMouth™ X-Pipe. Both systems feature a pair of 3-1/2-inch dual-wall, polished stainless steel tips. The modular design lets you convert the LoudMouth™ system to a quieter LoudMouth II™ system in minutes, by purchasing a pair of bolt-on LoudMouth II™ bullet-style mufflers (#31063). Manufactured using 2-1/2-inch stainless steel tubing and covered by our Limited Lifetime Warranty.

31560 LoudMouth™ Exhaust System with PowerFlo™ X-Crossover Pipe, 2005-2006 GTO

31561 LoudMouth II Exhaust System with PowerFlo™ X-Crossover Pipe, 2005-2006 GTO



2004 GTO LoudMouth™ and LoudMouth II™ systems

SLP's 2004 GTO LoudMouth™ and LoudMouth II™ systems include an integral X-pipe crossover and specially designed bullet-style resonators or mufflers to provide superior flow and performance. Like all SLP exhaust systems, the GTO LoudMouth™ and LoudMouth II™ systems are manufactured from 100% stainless steel tubing and carry our Limited Lifetime Warranty.

31060 LoudMouth™ Exhaust System with X-Pipe, 2004 GTO

31061 LoudMouth II™ Exhaust System with X-Pipe, 2004 GTO

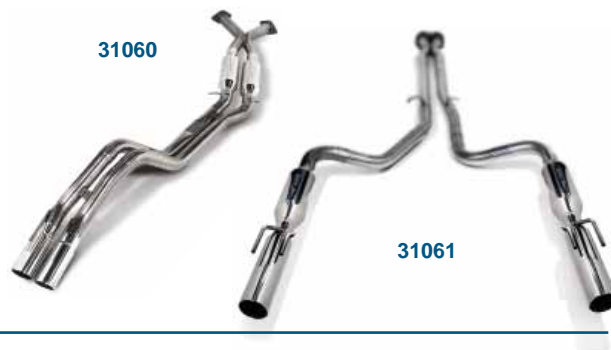

LoudMouth™ and LoudMouth II™ Bullet-Style Resonators and Mufflers

SLP's LoudMouth™ and LoudMouth II™ Bullet-Style Resonators and Mufflers allow you to switch between the two by simply loosening a few OEM-quality band clamps, swapping the mufflers, and retightening. Each SLP muffler type boasts its own unique tone and flow characteristics, allowing you to custom-tailor your vehicle's exhaust system to suit virtually any on or off-road application.

31062 LoudMouth™ Resonator, GTO (pair)

31063 LoudMouth II™ Bullet-Style Muffler, GTO (pair)



Braking Components

2004 GTO Custom Fit Brake Control Package

An SLP-exclusive, this 2004 GTO Custom Fit Brake Control Package is designed to fit both automatic and manual transmission GTO applications. Here's how it works for racing: Press the brake pedal and flip the brake-control solenoid switch on. Remove your foot from the pedal, and the solenoid maintains line pressure to the front brakes until the switch is released. This makes it easy to heat the rear tires in the burnout box, while minimizing wear and tear on your car's rear brake components. When racing your GTO on the track, the system can help to prevent a manual-equipped car from rolling out of the staging beams at the starting line. This package is custom-fitted to the GTO chassis and is compatible with the factory anti-lock braking and traction-control systems. It includes a waterproof electronic solenoid, CNC pre-bent steel lines with OEM fittings, all necessary mounting hardware, and detailed installation instructions.



24050 Brake Control Package, 2004 GTO only

020758121 Service Solenoid

NOTE: Additional modifications required.

GM TRUCK/SUV

2007-2015 900 Series Silverado, Sierra, Avalanche,
Tahoe, Suburban, Yukon/XL/Denali, Escalade



GM Truck/SUV Superchargers

with available 3/36 Powertrain Warranty

Roots-Type Supercharger

SLP's Roots-Type Superchargers are now available for 2009-2013 GM Trucks and SUVs. The SLP Stage I Supercharger Kit delivers more than 500 horsepower and 500 lb-ft of tire-shredding torque to the ground. Even after the industry-conservative drivetrain loss of 12%, the SLP kit yields 575 horsepower (450 HP, 1900 5.3L kit) at the crank, utilizing 91 octane pump gas, stock exhaust manifolds, stock catalytic converters, and the factory air box. Highly-developed SLP calibrations guarantees the absence of any shortcuts that might risk the safety of your engine, vehicle, or legality.

The Stage I Kit contains everything necessary to install the kit.

92020A	1900 Series Stage 1 Supercharger Package, 2009-2013 Silverado/Sierra/SUV with 5.3L
403274	Replacement Belt (1900 Series)
92025A	2300 Series Stage 1 Supercharger Package, 2009-2013 Silverado/Sierra/Yukon Denali with 6.2L
904068232	Replacement Belt (2300 Series, 98 mm pulley)
620025	Tuner Kit – 2.3L
90001	Optional 3-Year/36,000-Mile Limited Powertrain Warranty

NOTE: SLP's optional powertrain warranties are NOT a third-party warranty and have NO DEDUCTIBLE.

Available Alternative Pulleys and Belts (2300 only)

PULLEY P/N	DIAMETER	BELT P/N
90 46 30127	74 mm	—
HH-6K98-AA	98 mm (stock)	904068232
92002	91 mm	—

Unique Features of SLP's All-New ROOTS-TYPE Supercharger

- Designed from a clean sheet of paper to meet or exceed all OEM design, engineering, and manufacturing standards
- Direct drive rotor pack eliminates the need for a jackshaft, extra bearings, extra pulleys, and rear belt
- Intake manifold ports are port-matched (designed into casting) to the cylinder head ports for greater airflow
- Easiest supercharger installation on the market; installs in less than 8 hours
- Includes OEM-quality plug-and-play wire harnesses, pre-bent and pre-cut hoses
- New 2 bar MAP sensor allows more accurate fuel delivery under boost conditions
- Patented distinctive SLP outer case design mimics the inner helix design of the rotor pack
- Intercooled with high-flow circulating pump and oversized coolant reservoir to maximize thermal capacity
- Includes new belt tensioner with higher tension and greater travel compared to stock. Eliminates throwing belts even on 427 LS engines with 12 psi of boost



- Higher-flow air intake tube and new bellows included in Stage 1 kits
- Includes Hand-Held Touch-Screen Programmer with SLP-developed and pre-loaded custom PCM calibrations for each specific SLP supercharger package
- Most competitively priced TVS superchargers on the market. The SLP systems create the most horsepower per dollar.
- SLP's GM Truck supercharger uses Eaton's TVS series rotor packs, the same rotor packs used in GM's ZR1 Corvette engine
- Injector bosses cast into manifold at same angle as GM's manifold, providing optimum fuel delivery to the back of the valve for improved combustion and atomization of fuel
- 3-YEAR/36,000-MILE WARRANTY ON ALL SUPERCHARGER COMPONENTS
- E.O. #D-187-21

Cold Air Induction Systems

SLP'S Blackwing™ Cold Air Induction Systems replace the restrictive, power-robbing factory air cleaner assemblies found on 1999-2013 4.8/5.3/6.0/6.2L Silverado/Sierra/SUVs. They improve performance by picking up cool, dense outside air and directing it into the engine. These Cold Air Induction Systems provide up to a 10 horsepower increase by improving inlet airflow through a more efficient design consisting of a larger-than-stock high-flow conical Blackwing™ air filter, a larger diameter composite intake tube and larger air-box housing. Includes all necessary hardware and detailed installation instructions.

21051 Blackwing™ Cold Air System, 1999-2007 Silverado/Sierra/SUV (classic models)

21052 Blackwing™ Cold Air System, 2007-2008 Silverado/Sierra/SUV

21053 Blackwing™ Cold Air System, 2009-2013 Silverado/Sierra/SUV

NOTE: Filter Cleaner and Oil Kit #25017 is required when cleaning/re-oiling your filter.

Blackwing™ Filter Cleaner and Oil Kit

Blackwing™ Filter Cleaning and Oil Kit required for all SLP Blackwing™ oiled filters.

25017 Blackwing™ Filter Cleaner and Oil Kit



Performance Components

Underdrive Pulley/Harmonic Balancer

SLP's Underdrive Pulley/Harmonic Balancer reduces accessory drive speed by 25%, increasing the engines power output by up to 5 horsepower. Features 100% steel construction and extra-tall belt retention walls that eliminate belt slippage.

100230A 1999-2013 4.8/5.3/6.0/6.2L Silverado, Sierra, All SUVs

NOTE: New belts are required for each application. Please contact SLP for proper belt part numbers.



160° Thermostat

Reduces coolant temperature, easy to install, and requires no additional modification. SLP 160-degree Lower Temperature Thermostats are a cost-effective way to improve your truck or SUV's performance.

100229 2007 1/2-2013 4.8/5.3/6.0/6.2L



Exhaust Systems

SLP's LoudMouth III™ Stainless Steel Exhaust Systems improve the power and efficiency of the 2009-2013 GM Trucks and SUVs equipped with 5.3L, 6.0L (6.0L up to 2009 only) or 6.2L engines. SUV Exhaust Systems are available with side-exit dual and single outlets, unlike most other systems currently available. You can expect increases of up to 12 horsepower, depending on the application, along with a deep muscle car rumble and no cabin resonance. SLP's unsurpassed product quality enables us to provide a Limited Lifetime Warranty on all exhaust systems and components.

Silverado/Sierra Dual Rear-Exit Cat-Back LoudMouth III™ Exhaust System

SLP's Silverado/Sierra Dual Rear-Exit Cat-Back LoudMouth III™ Exhaust System features CNC mandrel-bent stainless steel tubing, a polished 304 stainless steel, and a low-restriction muffler that meets applicable state and federal drive-by noise standards. The catalyst-back system includes two high-quality polished 304 stainless steel dual wall exhaust tips that exceed the quality of the factory tips, 45-degree side-exit adapters, OEM-style hangers and clamps that fit factory attachment points, all necessary hardware and detailed installation instructions. System fits with spare tire in place.

31047 LoudMouth III™ Cat-Back Dual Exhaust System, fits 2009-2013 5.3L/2009 6.0L, Silverado/Sierra, Extended/Crew Cab w/Rear Drum Brake Models Only

NOTE: Exhaust Hanger #31047H is required when ordering for 2010-2013 models.



45° Side Exit Adapters Included

Silverado/Sierra Dual Rear-Exit LoudMouth III™ Axle-Back Exhaust System

SLP's Silverado/Sierra Dual Rear Exit LoudMouth III™ Axle-Back Exhaust System for the 6.2L engine eliminates the single-sided factory system and features dual CNC mandrel-bent stainless steel tubing from the muffler back, providing a true dual rear-exit system. The axle-back system includes two high-quality polished 304 stainless steel dual wall exhaust tips that exceed the quality of the factory tips, OEM-style hangers and clamps that fit factory attachment points, all necessary hardware, and detailed installation instructions. System fits with spare tire in place and will work with the SLP Sport Suspension.

31099A LoudMouth III™ Axle-Back Dual Exhaust System, fits 2009-2013 6.2L Silverado/Sierra, Extended/Crew Cab



Avalanche/Suburban Dual Side-Exit Cat-Back LoudMouth III™ Exhaust Systems

Our Avalanche/Suburban Dual Side-Exit Cat-Back LoudMouth III™ Exhaust Systems for the 5.3L engines feature CNC mandrel-bent stainless steel tubing and a polished 304 stainless steel low-restriction muffler that meets applicable state and federal drive-by noise standards. Catalyst-back systems include dual wall quad round tips or two trapezoid shaped tips. Both are high-quality polished 304 stainless steel. Also included are OEM-style hangers and clamps that fit factory attachment points, all necessary hardware, and detailed installation instructions.

31690 LoudMouth III™ Dual Exhaust System, with Quad Round Tips, fits 2009-2013 5.3L Avalanche, Suburban

31691 LoudMouth III™ Dual Exhaust System, with Dual Trapezoid Tips, fits 2009-2013 5.3L Avalanche, Suburban



Avalanche/Suburban Single-Side Cat-Back LoudMouth III™ Exhaust System

SLP's Avalanche/Suburban Single-Side Cat-Back LoudMouth III™ Exhaust System for the 5.3L engine features CNC mandrel-bent stainless steel tubing and a polished 304 stainless steel low-restriction muffler that meets applicable state and federal drive-by noise standards. Includes the same high-quality dual round tips found in our dual rear-exit system. Also includes OEM-style hangers and clamps that fit factory attachment points, all necessary hardware, and detailed installation instructions.

31692 LoudMouth III™ Single-Side Exhaust System, with Dual Tips, fits 2009-2013 5.3L Avalanche, Suburban



Escalade/Yukon Denali Dual Side-Exit LoudMouth III™ Axle-Back Exhaust System

SLP's Yukon Denali Dual Side-Exit LoudMouth III™ Axle-Back Exhaust System for the 6.2L engine eliminates the single-side factory system and features dual CNC mandrel-bent stainless steel tubing from the muffler back providing a true dual side-exit system. This axle-back system includes two high-quality polished 304 stainless steel dual round exhaust tips that exceed the quality of the factory tip, OEM-style hangers and clamps that fit factory attachment points, all necessary hardware and detailed installation instructions. System fits with spare tire in place and will work with the SLP Sport Suspension.

31098A LoudMouth III™ Dual Side-Exit Axle-Back Exhaust System, fits 2009-2013 6.2L Escalade/Yukon Denali

NOTE: Exhaust System does not fit Platinum Edition with rear fascia exhaust outlets.



Dual 3-1/2-inch Diameter Exhaust Assemblies

SLP's Dual 3-1/2-inch Diameter Exhaust Assemblies work with the stock 2007-2013 Silverado, Sierra, Avalanche, Tahoe, Suburban, Yukon, Yukon XL, Yukon Denali, and Escalade exhaust systems, and are available for models with 5.3L and 6.2L engines. The stock unpolished single tip is removed before our easy-to-install 304 stainless steel polished dual-tip assembly is clamped in place. All necessary hardware and complete installation instructions are included.

- 31059** 2007-2013 Avalanche, Tahoe, Suburban, Yukon, Yukon XL, 5.3L
- 31093** 2007-2013 Silverado, Sierra 1500/2500/3500, 5.3L
- 31096** 2007-2013 Yukon Denali, Escalade, 6.2L



Stock



SLP Dual Tip

Appearance

Front Bumper/Fascia Overlay Panels Two-Piece Tape-On Hood Scoop

SLP's Two-Piece Tape-On Hood Scoop features a hidden recessed tape flange (1) which hides the tape for a flush, OEM look. Includes molded-in mounting pins (2) with speed nuts (which can easily be removed) for a solid mechanical attachment if you choose to use them. Easily installs in 30 minutes. Comes ready for prep, prime, and paint. Includes all necessary hardware, tape, and complete installation instructions.

10005 2002-2013 Silverado, unpainted



Dead Pedal

SLP's Dead Pedal is a must-have for every 2007-2013 1500 Series Silverado, Sierra, Avalanche, Tahoe, Suburban and Yukon. Our easily installed Dead Pedal provides a place to rest your foot at a comfortable angle. Simply remove the left side inner kick panel (it just snaps into place), drill three holes with the supplied template, bolt the dead pedal into place, and reinstall the kick panel. It's manufactured from aircraft quality aluminum, with a black anodized finish and three grip strips.

40110 2009-2013 Silverado, Sierra, Avalanche, Tahoe, Suburban, Yukon, Escalade



TRAILBLAZER SS



Trailblazer SS

Exhaust System with Rear Fascia Panel

LoudMouth III™ Dual Exhaust System

SLP's LoudMouth III™ Dual Exhaust System for the Trailblazer SS is handcrafted from stainless steel. It includes a 3-inch intermediate pipe and 2-1/2-inch tailpipes, bent on state-of-the-art CNC bending equipment to create smooth mandrel bends to minimize exhaust gas restrictions. Includes a fully-polished 304 stainless steel muffler with a stamped SLP logo and a pair of distinctive 4-inch dual-wall polished stainless tips. The system is covered by our Limited Lifetime Warranty and comes complete with all necessary hardware and detailed installation instructions.

Trailblazer SS LoudMouth III™ Exhaust System Features:

- Easy bolt-on installation
- Handcrafted from 3-inch and 2-1/2-inch stainless steel
- Distinctive 4-inch dual-wall polished stainless tips
- Limited Lifetime Warranty
- A dual-opening OEM-quality rear fascia panel that is ready for prep, prime, and paint

31675 LoudMouth III™ Dual Exhaust System with Rear Fascia Panel, 2006-2009 Trailblazer SS, unpainted

Rear Fascia Panel

The Rear Fascia Panel is manufactured from flexible high-impact ABS for ease of installation. It is also available as a separate part number, and comes ready for prep, prime, and paint.

31675V Rear Fascia Panel Only, 2006-2009 Trailblazer SS, unpainted



Appearance

SLP's injection molded Two-Piece Tape-On Hood Scoop (Patent #D0528482) features a hidden recessed tape flange (1) which hides the tape for a flush OEM look. Includes molded-in mounting pins (2) with speed nuts (which can easily be removed) for a solid mechanical attachment if you choose to use them. Easily installed in 30 minutes. Comes ready to prep, prime, and paint. Includes all necessary installation hardware, tape, and complete mounting instructions.

10005 2006-2009 Trailblazer SS, unpainted



ACCESSORIES

Windshield Banners

SLP Windshield Banners will let everyone know SLP products power your vehicle. Available in silver, white, and red with a curved design, and a silver version with a straight design, these banners will enhance the appearance of any SLP-modified car, truck, or SUV. Easy to install.

100017A SLP Banner, Silver



License Plate Frame

Tell them you've got SLP power on your side! Our license plate frame is a simple black design with the SLP Performance Parts logo at the bottom in raised white lettering.

59399 SLP License Plate Frame



SLP Logo Badge Set

SLP now offers an OE-quality chrome plated over a flexible plastic SLP logo badge. Featuring a reflective chrome red "SLP" inlay with a chrome surround, each beveled-edge badge is manufactured to the highest quality OE standards and designed to last for years. Whether your vehicle is highly-modified or you're looking for a personal yet subtle touch, SLP's chrome badge creates the look that gets your vehicle noticed. Pre-applied die-cut adhesive tape ensures an easy installation and measures 3/4-inch high x 5-3/4-inch in length to fit any car or truck. Backed by our 90-Day SLP Parts Limited Warranty and sold as a pair, this new badge is a must-have for any die-hard SLP enthusiast and makes a perfect gift without breaking the bank!

620026 SLP Logo Badge Set



Leather-Wrapped Shift Knobs

Leather-wrapped shift knobs for 1984-2002 5-speed and 6-speed F-bodies. Embossed with the SLP logo or "H" logo.

60081 Shift Knob, 1984-2002 5/6-Speed Shifter, Leather-Wrapped with "H" embossed logo, Black

10416 Shift Knob, 1984-2002 5/6-Speed Shifter, Leather-Wrapped with SLP embossed logo, Black



60081



10416

Supercharger Custom Boost Gauge Pod

SLP's exclusive Supercharger Custom Boost Gauge Pod is designed for use on all 2005-2013 C6 Corvettes equipped with an SLP or other TVS 2300 Supercharger Package.

90540A Gauge Pod Only

90541A Boost Gauge Only

90542A Boost Gauge and Gauge Pod



ENGINE COMPONENTS



Windage Tray Spacers

The LS1, LS2, LS3, and LS7 stroker engine crank will not clear the factory windage tray. These spacers are required to move the tray down and away from the crank in order to maintain proper clearance in stroker crank engines. Kit includes ten (10) spacers.

12510 Spacers, Windage Tray, ZL engines (set of 10)



LS1 Oil Pump

Stock LS1 oil pumps have been known to fail without warning, causing extensive, (and expensive) engine damage in the process. To prevent this, SLP has developed a ported and blueprinted LS1 Oil Pump that is virtually bulletproof under the most severe racing conditions. Surprisingly affordable, it's an ideal complement to our Double-Roller LS1 Timing Chain (#55000).

55001 Heavy-Duty Oil Pump, 1997-2007 LS1/LS6/LS2



Flow Booster

LT1/TPI Throttle Body Flow Booster

SLP's LT1/TPI Throttle Body Flow Booster improves air flow at the entrance of your throttle body. This airfoil-shaped piece smooths airflow into the throttle body and adds up to 7 additional horsepower. The Flow Booster is manufactured from aircraft-quality cast aluminum and includes all installation hardware and instructions for easy bolt-on installation. For maximum benefit, add an SLP Cold Air Package. E.O. Approved.

22100 Throttle Body Flow Booster, 1985-1997 LT1/TPI



Balancer/Pulleys

Smaller-Diameter W-Body Supercharger Pulley

SLP's Smaller-Diameter W-Body Supercharger Pulley works with all supercharged 3800 GM engines. This pulley helps your engine produce up to an additional 25 horsepower, without compromising. SLP's pulley is constructed from OEM-quality steel and has a black OEM finish for a stock, under-hood look. The pulley utilizes the original factory drive belt and is available separately.

100227A Pulley Only, 1997-2008 3800 Supercharged

NOTE: FOR OFF-ROAD USE ONLY.



Harmonic Balancer/Underdrive Pulleys

SLP's Harmonic Balancer/Underdrive Pulleys reduce accessory drive speed by 25%, increasing your engine's power output by up to 5 horsepower. These balancer/pulleys for LS1/LS6/LS2/LS3/L76/L99 engines incorporate a number of high-quality features you won't find on any other aftermarket unit. Among them are a pair of extra-tall belt retention walls that eliminate the belt slippage issues common with other LS balancers. Other unique design strengths include 100% steel construction (other brands use steel and aluminum), integral timing marks, and built-in puller-mounting threads. Includes a new balancer bolt and detailed installation instructions.



100221	Harmonic Balancer/Underdrive Pulley, 1998-2002 LS1 Camaro/Firebird
100225	Harmonic Balancer/Underdrive Pulley, 1997-2013 LS1/LS6/LS2/LS3 Corvette, 2008-2009 L76 Pontiac G8, 2009 Pontiac G8 GXP
100226	Harmonic Balancer/Underdrive Pulley, 2004-2006 GTO

100230A	Harmonic Balancer/Underdrive Pulley, 2010-2015 L99/LS3 Camaro, 1999-2007 GM Truck/SUV 4.8/5.3/6.0L, 2007-2013 5.3L/2007-2009 6.0L GM Truck/SUV, 2006-2009 Trailblazer SS
100232A	Harmonic Balancer/Underdrive Pulley, 2010-2015 V6 Camaro

NOTE: New belts are required for each application. Please contact SLP for proper belt part numbers.

HEMI Harmonic Balancer/Underdrive Pulleys

SLP's 25% underdrive balancer for Mopar HEMI V8's incorporate a number of high quality features you won't find on any other aftermarket unit and makes up to 9 additional rear wheel horsepower and 10 lb-ft of rear wheel torque over the stock crankshaft pulley. Each pulley features a pair of extra tall belt retention walls that eliminate the belt slippage issues common with other balancers, it is black powder-coated and SFI approved. Other unique design strengths include a 100% steel construction (other brands use aluminum), integral timing marks and built in puller mounting threads. Includes detailed installation instructions.



Features:

- Up to 9 Rear Wheel Horsepower Increase
- Up to 10 lb-ft Rear Wheel Torque Increase
- Extra-tall belt-retention "walls" no more thrown belts!
- 100% steel construction
- Black powder coated
- SFI approved
- Integral timing marks and puller-mounting threads
- Does not cause false knock retard or erratic power-curve dips

NOTE: Requires new belt – Dayco 5060800/Gates 6PK2030 or similar for Challenger/Charger SRT8 6.4L. For all other listed applications please measure for proper belt size.

100235	2005-2008 Charger/Magnum/300 5.7L/6.1L, Challenger 6.1L Harmonic Balancer/Underdrive Pulley
100236	2011-2013 6.4L Dodge Charger, Challenger, Chrysler 300 RWD, Jeep Grand Cherokee, 2011-2013 5.7L Chrysler 300, 5.7L Jeep Grand Cherokee, 5.7L Dodge Charger, Challenger, 2012-2013 5.7L Dodge Durango

Timing Chains

LS1, LS2 and LS3 Double-Roller Timing Chains

Our LS1, LS2 and LS3 Double-Roller Timing Chains are perfect complements to our high-performance camshafts and other engine components. They each offer greatly-enhanced strength and durability compared to the stock piece and even allow for precise cam timing adjustments (advance or retard) of up to 8-degrees. The sets contain an adjustable, nine-keyway nitrated crankshaft sprocket, a double-roller chain, two oil-pump-spacer plates, all necessary hardware, and detailed installation instructions. The LS1 is compatible with all 1997-2003 third-generation engines (LS1, LS6, 4.8L, 5.3L, 6.0L), the LS2 is compatible with all LS2 engines, and our LS3 is compatible with all LS3 engines.

55000	Double-Roller Timing Chain, 1997-2004 LS1/LS6
55003	Double-Roller Timing Chain, 2005-2006 LS2
55004	Double-Roller Timing Chain, 2008-2013 LS3
55002	Heavy-Duty Oil Pump/Timing Chain Package, 1997-2004 LS1/LS6

Save by purchasing the LS1 Double-Roller Timing Chain and our LS1 Oil Pump #55001 together!



160° Thermostats

Reduces coolant temperature, easy to install, and requires no additional modification. SLP 160-degree Lower Temperature Thermostats are a cost-effective way to improve your vehicle's performance.

100223	160° Thermostat, LS1 1997-2003 Corvette, 1998-2002 Camaro and Firebird, 1997-2003 4.8/5.3/6.0 Silverado, Sierra, and SUV
100224	160° Thermostat, 1992-1997 LT1 Camaro/Firebird, 1992-'96 LT1 Corvette
100228	160° Thermostat, 2008-2009-1/2 L76 Pontiac G8, 2004-2008 LS1/LS6/LS2/LS3/LS7 Corvette, 2004-2006 LS1/LS2 GTO, 2004-2006 4.8/5.3/6.0 Silverado, Sierra, SUV, 2007 Classic, 2006 Trailblazer SS
100229	160° Thermostat, 2010-2015 LS3/L99 Camaro, 2009-2013 LS3/LS7 Corvette, 2009-1/2 L76 Pontiac G8, 2009 G8 GXP, 2007-2013 4.6/5.3/6.0/6.2 Silverado, Sierra, SUV 900 Series, 2007-2009 Trailblazer SS



EXHAUST SYSTEM

Components



Bullet-Style Resonators



310013919 2.5-inch Resonator – Single – LoudMouth™
31062 2.5-inch Resonator – Pair – LoudMouth™

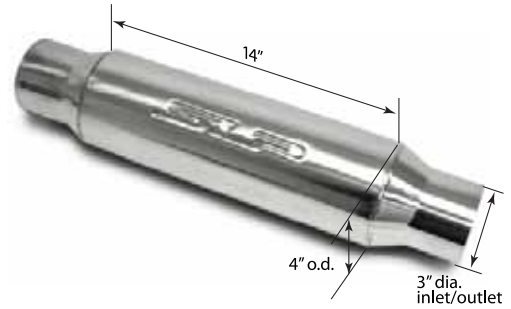

310301660AM 3.0-inch Resonator – LoudMouth™

Bullet-Style Mufflers

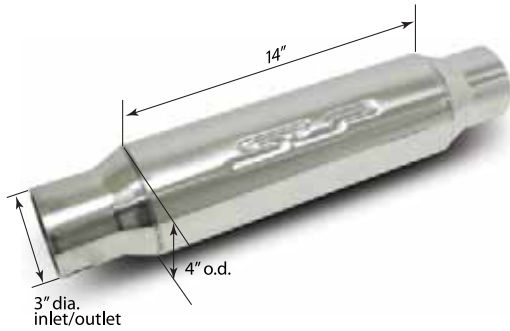

31067 3-inch Bullet Muffler – LoudMouth II™

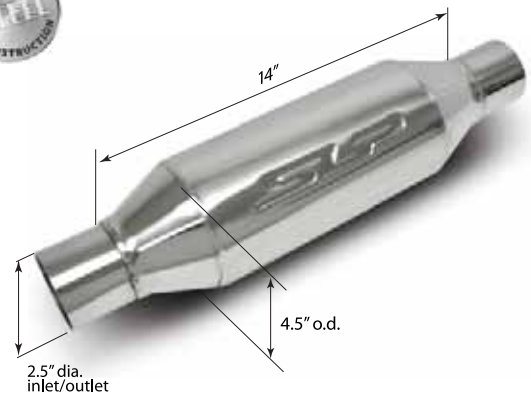

310013818 2.5-inch Bullet Muffler – Single – LoudMouth II™
31063 2.5-inch Bullet Muffler – Pair – LoudMouth II™

Universal-Style Mufflers



308560782 Muffler – Single – LoudMouth III™
31065 Muffler – Pair – LoudMouth III™

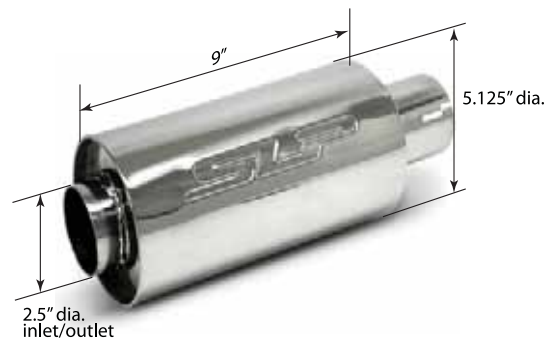

310560401 Muffler – LoudMouth III™

Universal-Style Mufflers



310559795 Chambered Muffler – LoudMouth III™



310040112 Muffler – LoudMouth II™



310650800 Muffler – LoudMouth III™

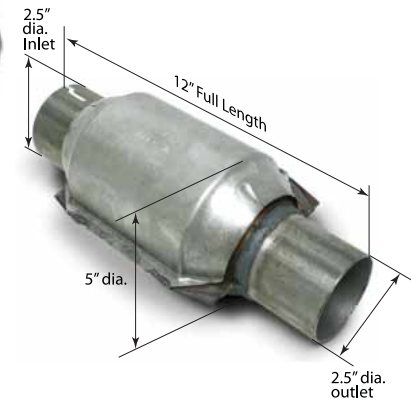

M310193500 Catalytic Converter – Single

M31040 Catalytic Converter – Pair



300525507NH Muffler – LoudMouth III™

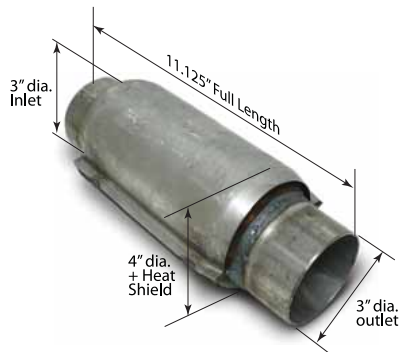

813000001 Catalytic Converter



310040113 Muffler – LoudMouth II™

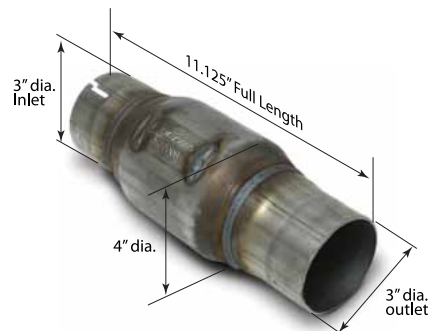

301134001 Catalytic Converter

Premium Exhaust Clamps



308144380 Universal Band 2-1/2-inch Clamp



10640 Universal Band 2-1/4-inch Clamp



308940020 Universal Band 3-inch Clamp



310301491 Rubber Hanger



308303902 Universal Uni-Bolt 2.5-inch Clamp

Tips



310305080 4-inch Dual-Wall, Slash-Cut



310305800 3.5-inch Dual-Wall, Slash-Cut



10271 Universal Band 2-7/8-inch Clamp



310815628 4.125-inch Dual-Wall, Slash-Cut



M31039 4.125-inch Dual-Wall, Slash-Cut

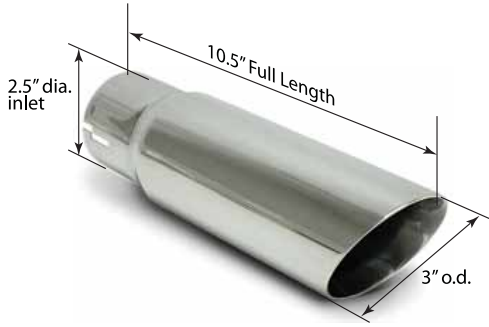

307815422 3-inch Dual-Wall, Slash-Cut

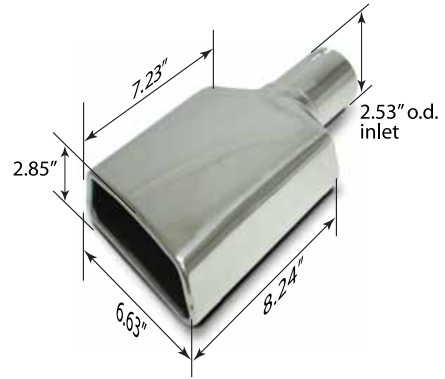

310301618 6.63-inch Single-Wall, Rolled Edge, Trapezoid, Angle Cut, Driver-Side

310301617 6.63-inch Single-Wall, Rolled Edge, Trapezoid, Angle Cut, Passenger-Side

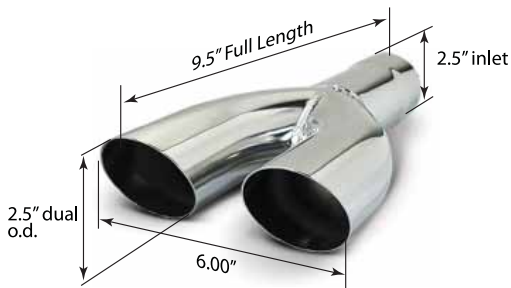

310305100HP 2.5-inch Single-Wall, Dual, Driver-Side

310305107HP 2.5-inch Single-Wall, Dual, Passenger-Side



310601805 Tip Assembly, Rear Exit Style

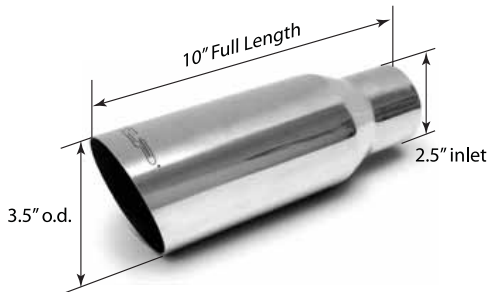

310305302HP 3.5-inch Single-Wall, Slash-Cut



310301859 Tip Assembly, Side Exit Style

SLP Limited Warranty

This limited warranty supersedes and replaces all previously published warranties. There are NO OTHER warranties expressed or implied on SLP Performance Parts products. SLP Performance Parts warrants its products to be free from defects in material and workmanship as follows:

- Headers and Exhaust Products: Limited Lifetime*
- Composite Body Parts: 1 Year
- Engines: 1 Year
- Engine Components: 90 Days
- Wheels: 1 Year
- Suspension Parts: 90 Days
- Accessories (shifter knobs, wheel-lug or center caps, car covers, emblems, etc.): 90 Days
- Cold-Air Intake Systems (excluding filters): Limited Lifetime*
- Programmers: 2 Years
- Transmission/Driveline: 90 Days
- Electrical Products: 30 days
- Superchargers: 3/36**
- Painted Parts: 1 Year

SLP's parts are warranted from the original purchase date shown on the sales invoice. A copy of the original dated sales receipt must accompany any part that is returned because of a warranty claim. During the warranty period, SLP Performance Parts will repair or replace, at its discretion, any product found to be defective in material or workmanship. All products must be returned with shipping costs prepaid to SLP Performance Parts in Plymouth Township, Michigan. C.O.D. shipments will be refused. It is the customer's responsibility to obtain an RGA (return authorization) number from the SLP Performance Parts Customer Service Department (855-757-7373) before returning any product.

In the event of a possible defect in material or workmanship, the responsibility of SLP Performance Parts, Inc. is strictly limited to the repair or replacement of the SLP product. SLP Performance Parts, Inc. is not responsible for improper installation, incidental and consequential damages, property damage, personal injury damages, labor costs, transportation or other incidental or consequential charges; or storage or rental-car charges, to the extent permitted by law.

SLP Performance Parts products are designed to work on stock, unmodified vehicles, as supplied by the original manufacturer. Due to the complexity and variety of modifications possible, SLP Performance Parts makes no claims as to the merchantability or fitness of any part. Rather, it is up to the purchaser to determine if the part is compatible with his/her application.

Any product shipped in error (the wrong part), will be replaced with the correct part at no charge. The replacement part(s) will be shipped at no cost, by the same shipping method that the original order was shipped and a call tag will be issued to pick up the parts that were originally shipped in error. We will NOT upgrade the shipping method.

Example: If you ordered the products to be shipped by normal freight, it is the responsibility of the customer or installation facility to inspect ALL parts and determine if the products are correct, prior to installation or disassembly.

The following are specifically excluded from the SLP warranty:

1. Parts altered, modified, or used in applications not specifically noted in the SLP Performance Parts application guide.
2. Damage from misuse, improper installation, or unauthorized repairs or maintenance (including consequential damage).
3. SLP Performance Parts specifically disclaims responsibility for any of its products' compatibility with aftermarket parts produced by other companies or with vehicles that have been otherwise modified.
4. Labor to remove or replace the part(s). Fluids, gaskets, incidental parts, and shipping costs are not covered.
5. Incidental or consequential damages, including labor or diagnostic charges to determine failure.
6. Repairs to SLP Performance Parts products performed by unauthorized persons or organizations.
7. Costs for vehicle downtime or loss of vehicle use due to inoperability.
8. Normal wear and tear.
9. Prep or paint charges for any body part not trial-fit or -inchseasoned-inch per SLP Performance Parts instructions before painting.
10. Products used for racing.

* Limited Lifetime Warranty for Headers, Exhaust, and Cold-Air Systems: Headers and exhaust components are warranted for life against rust, corrosion, failed welds, cracks, and similar defects under normal use. Discoloration of coatings is NOT covered. Damage caused by excessive heat (from lean combustion or use of -inchheat wraps-inch), flood, collision, modification, or road hazard IS NOT COVERED. All other aforementioned exclusions apply. Product must be returned, freight prepaid, to SLP Performance Parts in Plymouth Township, Michigan for evaluation. After evaluation SLP Performance Parts will, at its discretion, repair or replace the part. In the case of headers, only the affected part(s) will be repaired or replaced.

Cold-air inductions/air boxes are warranted for life against rust, corrosion, failed welds, cracks, and similar defects in material or workmanship under normal use. Appearance of coatings or finishes is warranted for 3 years. Damage from collision, alteration, misuse, or improper installation is not covered. Filters are not covered.

**Supercharger Parts Warranty: EATON TVS supercharger assemblies and components are warranted for 3 years or 36,000 miles from date of purchase. In order for this warranty to be in effect, the Supercharger warranty registration card must be filled out completely at time of sale, and mailed to SLP along with a copy of the original Invoice.

Supercharger warranty is limited to assemblies and components only, and covers defects in materials or workmanship. At our discretion, we will repair or replace any supercharger part that fails while the supercharger is in service within the warranty period. Warranty does not cover labor, consequential damage, failure due to improper air filtration, alteration, misuse, accident damage, faulty installation, faulty repair or when used in applications for which they were not designed or approved. Electrical parts including fuel and intercooler pumps only have a one year warranty.

These warranties give you specific legal rights, and you may have other legal rights, which vary from state to state. SLP reserves the right to modify its warranty policy without notice.



Call: 855-SLP-PERF
Fax: 734-466-6856
www.slponline.com

Printed in USA. Copyright 2014 SLP Performance Parts, Inc., Plymouth Township, MI USA.
SLP®, Muscle Car Central™, Loud Mouth®, Loud Mouth II®, Power-Flo®, PowerFlo-X™, ZL®, FlowPac®, and Blackwing® are trademarks of SLP Performance Parts, Inc., all rights reserved. Vehicle names in this catalog and their respective logos and emblems are trademarks and/or service marks of General Motors Corporation, its subsidiaries, affiliates or licensors, of Ford Motor Company, its subsidiaries, affiliates or licensors, or of Dodge/Chrysler, its subsidiaries, affiliates or licensors. Components shown in this catalog are manufactured by and for SLP Performance Parts and not General Motors, Ford Motor Company, or Dodge/Chrysler. SLP reserves the right to make changes at any time, without notice, to colors, materials, part specifications, availability, and pricing.